



GAMES WORKSHOP™

PRESENT THEIR MONTHLY GAMES MAGAZINE

WHITE DWARF™

£1.50

USA
\$3.50

AUSTRALIA
\$6.50

WEST GERMANY
DM 7.80

ORCS'N WARHAMMER ARMIES • WARPED REALM OF CHAOS
GOBBOS WEAPONRY
WARHAMMER 40,000: The Rhino Charges • Dwarf & Elf BLOODBOWL Teams



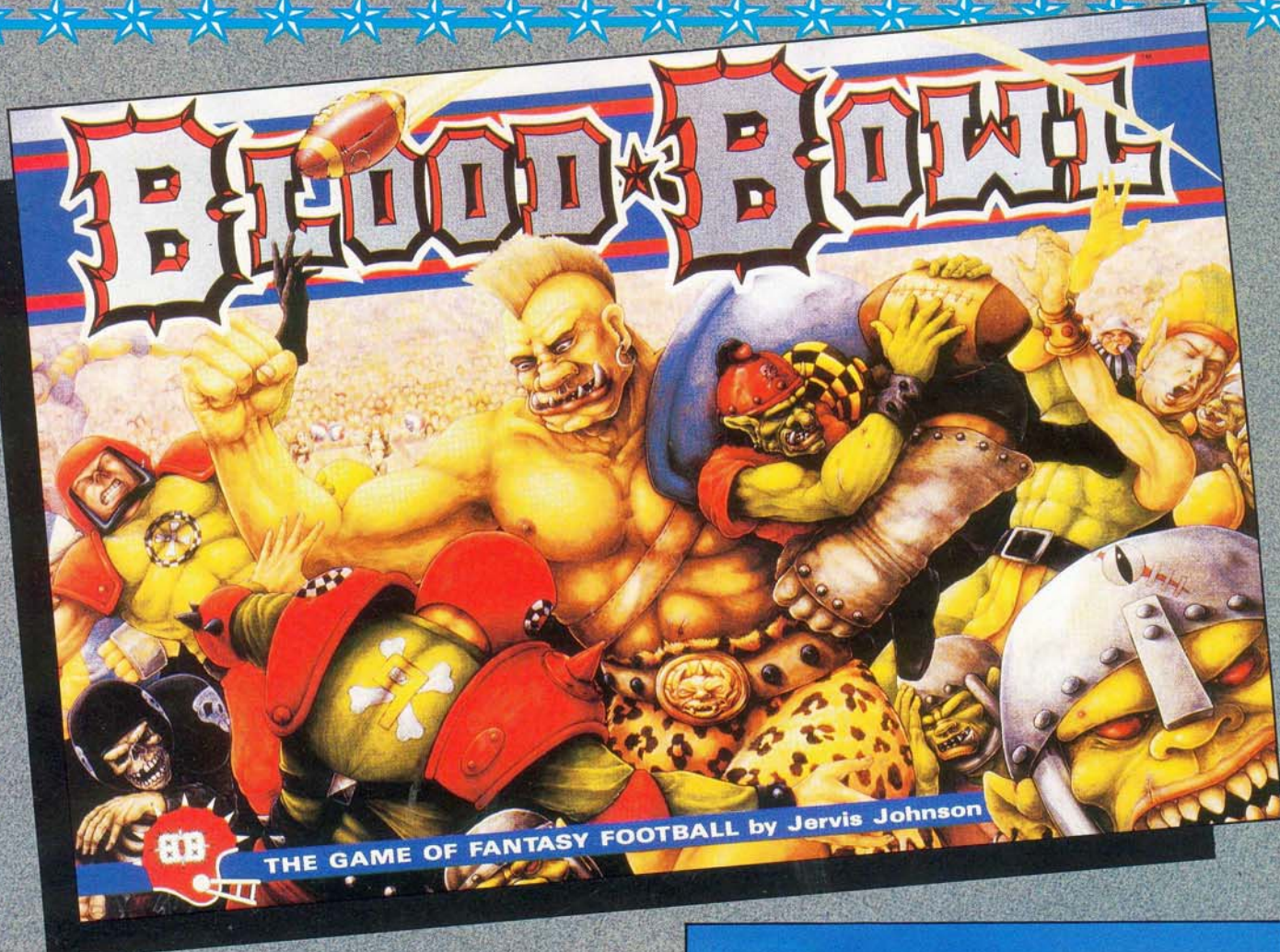

This is Blood Bowl - and *anything* can happen!
 Sports fans, the ancient ritual of the lost god Nuffle is back! And it's bigger, better, meaner and spikier than ever before!

Orcs, Humans, Dwarfs, Elves - all the major races of the Known World (and most of the minor ones too) have 'teams' of Warriors, mighty heroes who battle in great arenas for their people's honour, pride, and the sheer unmitigated hell of it!

Blood Bowl the game casts *you* in the role of a 'coach' of one (or more!) of these awe-inspiring teams. You decide the line-up, choose the tactics, and - at the end of the day - if you can get the best from your heavily armoured players (armed with only rippling muscles and spiked gauntlets), you can collect the ultimate prize, the honour and the glory of victory!

The package includes: two complete teams of hand-sculpted plastic miniatures in lifelike detail; a massive Astrogranite playing pitch in high-density, expanded polystyrene; the new mind-blowing Blood Bowl Handbook; plus completely revised and updated rules. You will be playing the basic game in minutes, adding extra systems for even greater realism as you master the game.

This is Blood Bowl! - where war is a whole new ball game!



**COMPLETELY NEW
 REVISED EDITION
 AVAILABLE JUNE**

Games Workshop,
 Chewton Street,
 Hilltop, Eastwood,
 NOTTINGHAM, NG16 3HY, UK

Games Workshop US,
 1220 Key Highway,
 Baltimore, Maryland,
 21230, USA

GAMES WORKSHOP™

WHITE DWARF

ISSUE 103 JULY 1988

Editorial Manager Phil Gallagher

Editor Sean Masterson

Contributors Mike Brunton, Graeme Davis, Dave Langford, Jervis Johnson, Derrick Norton, Rick Priestley, Ken Rolston and Nigel Stillman

Graphic Design Chris Colston, Mark Craven, Brian George and Bil Sedgwick

Art Editor John Blanche

Cover *Battlecars* Jim Burns

Illustration  Dave Andrews,  Paul Bonner,  Cradfax,  Carl Critchlow,  Colin Dixon,  H,  Gary Harrod,  Pete Knifton,  Ian Miller,  Russ Nicholson and  Sid

Production Dave Clemmett, Chris Colston, Nick Ord, Tony Osborne, Richard Wright and H

Miniatures Painters Sid, Mike McVey and Darren Matthews

Photography Phil Lewis

Typesetting Lindsey D Le Doux Paton and Dawn Duffy

Invaluable Typing Mary Anne Naismith

Advertising Tim Pollard

Publisher Games Workshop Limited

Print Buyer Bob Malin

Publications Manager Alan Merrett

Assistant Production Manager Steve Bruce

Studio Manager Tom Kirby

Head Honcho Bryan Ansell

Printed by Thamesmouth Web Offset, Basildon, UK.

All correspondence except subscriptions should be addressed to: *White Dwarf*, Games Workshop Design Studio, Enfield Chambers, 14-16 Low Pavement, Nottingham NG1 7DL.

Hello, come on in. There's a lot going on in here. When we get to Ken Rolston's Vermilion Pawn and meet Lukas Pfandleiher, be nice to him. Remember, it's carnival week in Middenheim and he's as busy as everyone else.

Perhaps we can interest you in some weaponry while you're here. Some fantastic workmanship has gone into this selection.

Generals, our definitive breakdown of goblinoid armies is hot off the classified list. You may also be surprised to learn the lethality of the latest in chaotic technology - unless you are chaotic, in which case, just take one of these pulverisers for a test maul. Please.

If it's a holiday you want, the galleries are filled to capacity with new, exciting works. I'm sure you'll enjoy taking them in on your tour. There's sport, too. Work off that weight - lose a limb.

Transport is available in a wide variety of colours and weapon payloads.

You have definitely come to the right place.



Sean Masterson

CONTENTS

CULTURE SHOCK	3
Barbeque your brain for summer.	
VERMILION PAWN	4
"Yeah, it's magical but how does it work?" Ken Rolston asks someone who should know.	
CRITICAL MASS	13
Dave Langford is on holiday this month, so...	
THRUD	14
Where is our hero going? Does he know? What unfortunate might cross his path?	
CHAPTER APPROVED	16
Warhammer 40,000 vehicles written off by Rick Priestley.	
LETTERS	25
The realm of readers.	
THE LONG AND THE SHORT OF IT	29
There are two sides to consider when Jervis Johnson presents rules for Elves and Dwarfs in <i>Bloodbowl</i> .	
ON THE BOIL	32
Graeme Davis answers questions on Characters and Careers in <i>WFRP</i> and finds that life isn't that hard after all.	
WEAPONS OF CHAOS	33
The biggest chunk of <i>Realm of Chaos</i> yet, hewn with what type of blade? Mike Brunton and Bryan Ansell examine the armoury.	
CRUSH, CRUMBLE AND CHOP	50
Stonking, spiky, swirling barrows of oblivion - the Tenderiser and the Whirlwind.	
'EAVY METAL	56
John Blanche with some Imperial custom jobs.	
ILLUMINATIONS	60
Hot metal and oil - in ink. Carl Critchlow.	
RAMPAGING RHINO	63
The colourful history of this M.41 AFV.	
GET DA BOYZ!	69
A Warhammer Armies assault led by goblinoids Rick Priestley and Nigel Stillman.	

SUBSCRIPTIONS Please send and make remittance to: Games Workshop, Chewton Street, Hilltop, Eastwood, Notts NG16 3HY (USA: Games Workshop US, 1220 Key Highway, Baltimore, Maryland, 21230 USA). Telephone (0773) 769731. *White Dwarf* is published monthly. Annual subscription details and rates are listed on p59. Please make all payments in Pounds Sterling. When you subscribe, please tell us whether you are renewing an old subscription or starting a new one.

When you want to inform us of a change of address or subscription renewal, or if you have a query, please write to Games Workshop, Chewton Street, Hilltop, Eastwood, Notts, NG16 3HY and make sure that you tell us your name and present address (and your old address if you are moving).

ISSN 0265-8712

OVERSEAS DISTRIBUTORS France: Citadel France, 5 Rue des Fetes, 75019 Paris. Italy: Pacific Enterprises Italia SRL, Via R.DI Lauria 15, 20149 Milan. Japan: Shinwa Corporation, Yamoto Building, 2-6-2 Iwamotoch, Tokyo. Australia & New Zealand: Ventura International, 3rd Floor, Shorter House, 193 Clarence Street, Sydney NSW 2000, Australia. USA: Games Workshop US, 1220 Key Highway, Baltimore, Maryland, 21230 USA. West Germany: Citadel GmbH, Muhlendam 41-43, 2000 Hamburg.

The publishers of *White Dwarf* regret they cannot accept responsibility for financial transactions between readers and advertisers.

White Dwarf reserves the right to amend or reject any material submitted for publication as an advertisement.

CONTRIBUTIONS The editor will be pleased to accept any previously unpublished articles or artwork for inclusion in *White*

Dwarf. Article submissions should be typed, double-spaced, on one side of A4 paper only. Artwork should be sent in photocopy or transparency form only. Please write for our submissions guidelines, enclosing a large SSAE or IRCs.

All subject matter in *White Dwarf* is copyright Games Workshop Limited.

All rights on the contents of this publication are reserved. Nothing may be reproduced in part or in whole without the prior written consent of the publishers.

© Games Workshop Limited 1988

Cover © Young Artists 1988

Blood Bowl, *Dark Future*, *Warhammer Fantasy Roleplay*, *Warhammer 40,000* and *Warhammer Fantasy Battle*, *Third Edition* are trademarks of Games Workshop Limited.

RHINO

MARINES

YOU ASKED FOR IT! YOU'VE GOT IT! A STARTLING NEW RANGE OF SPACE MARINES, ESPECIALLY POSED FOR USE WITH THE RHINO AND OTHER VEHICLES FROM CITADEL. THE MODELS (BLOOD DRINKERS IN THE PHOTOGRAPHS BELOW) COME IN A VARIETY OF POSES SO THAT THEY CAN BE POSITIONED AS HOLDING ONTO THE HANDRAILS OR RECLINING ON THE BODY. THERE ARE ALSO THREE TORSO MODELS (COMPLETE WITH HATCH PIECES) THAT CAN ACTUALLY BE BUILT ONTO THE MODEL. EQUIPPED AS A FULL FIGHTING CREW, THEY'RE ARMED, POWER-ARMOURED AND SPOILING FOR A FIGHT. BEAUTIFULLY MADE FOR COLLECTORS, FOR WH40K GAMES, AND MOST OF ALL, FOR SCARING THE GUMBLE-JUICE OUT OF THE ENEMY! DEFINITELY... CHAPTER APPROVED.



DESIGNED BY MARK COPPLESTONE · MODELS SUPPLIED UNPAINTED · RHINO'S NOT SUPPLIED

WARNING: THIS PRODUCT CONTAINS LEAD WHICH MAY BE HARMFUL IF CHEWED OR SWALLOWED. CITADEL MINIATURES ARE NOT RECOMMENDED FOR CHILDREN UNDER 12 YEARS OF AGE.

COPYRIGHT ©1988 GAMES WORKSHOP. ALL RIGHTS RESERVED.



CULTURE SHOCK

Ken Rolston returns to our pages this issue as the proprietor of the curiously named Vermilion Pawn. Ken's Dwarven magical mercantile venture marks the beginning of a new, occasional series of Compleat Encounters - FRP situations which incorporate interesting NPCs in adventure situations with locations and background material (such as new items or interesting treatments of creatures and items) for easy incorporation into a role playing session. Apart from being entertaining, it might give you some ideas for sending us *your* most intriguing NPC. **WFRP** situations are most wanted but we're also interested in *Cthulhu*, *Stormbringer*, *Dredd*, *RuneQuest*. In fact, the new WD submissions guidelines tell all, so write for yours if you're interested.

Why are GW games so popular? Ah, you don't win a prize for answering correctly. Think of the speeding metal of **Dark Future**, the grim peril of **WFRP**, the ironically colourful 41st millennium of **Warhammer 40,000**, the parody in **Blood Bowl**...

The trouble with a whole universe is the difficulty in getting it all into print. There's always another aspect to it that we don't have room to show you. Surely, plenty of people would be interested if we found a way of revealing a little more of the strange places, people and creatures that exist in the games?

Yes, but how?

We're going to produce a high profile, monthly adventure comic. After spending months of planning, thinking and 'getting our heads together', this graffiks extravaganza is now well underway, with artists and writers getting to work on their strips. Each strip is faithful to the game background it springs from. Some are blockbusting epics while others are more compact - they're all hard hitting.

The comic will open up and explore whole new areas of our worlds, and we're packing this monster with adventure from cover to (48 pages later) cover. We're talking to some of the most respected people working in the comic industry in this country. They're as excited as we are. Apart from the Famous Names who'll be appearing within its pages, we have found some new writers and artists - who you'll soon get very excited about. Betcha. Watch this space.

Meanwhile, Peterborough Rolegames' Gamesfest 88 convention took place on Saturday the 28th May at the Court Exhibition centre. A good time was had by all, even though there was still room to park a cross-channel ferry in the hall

where the event was held. Companies and groups held gaming sessions throughout the day. The relatively low attendance allowed everyone to explore the various games tables and dealer stands at their own pace. GW's stand was framed by 'Eavy Metal and Illuminations Live, which attracted enough interest to keep the stand's occupants busy talking, modelling, painting and drawing for the whole day. On top of all that was the regional Golden Demon heat. Some interesting music (wot no thrash?) helped add to the relaxed atmosphere. Organiser Mel Gilbert was pleased with the affair and is already planning next year's event.

Go on then, how many of you stayed up getting square-eyed during ITV's Telethon? Among the hundreds of events taking place under Telethon's banner, members of the Roundabout Youth Club got together for a marathon session of **Warhammer Fantasy Battle**. The lads had a good 24 hour bash (their report is currently on its way to *White Dwarf*). GW thanked the members of the group (who each received free games for their efforts), and Andy Jones organised a kaboodle of phenomenal proportions to be sent to the youth club's leader, Mr Robin Dews. He will be making sure that these goodies are now passed to a hospital - where some of the patients are bound to appreciate a break... Members of the club, together with Workshopppers in **Dark Future** gear, presented a cheque for £300 raised by the game.

GW sponsored Mythlore, those masters of the full sized beastie, in the Telethon director's challenge. Mythlore, who faced sixteen other teams in the competition, won the event with ease, even though the company's contestants were sweating out a Krypton Factor style assault course in full costume. A cheque for £20,000 was presented on behalf of all those taking part.

Southsea models became the second GW Specialist Stockist last month. They opened their doors to a fevered crowd of gamers on Saturday 14th May, when the enthusiasts were treated to a free hit on the head (from a rubber sword-wielding Workshoppper) with every purchase. Oh, all sorts of strange things happened. Go along to an opening when it happens near you.

Culture Shock extends congratulations and tentacles to BiL - who married the equally strangely named Gabz in May. May you both zog happily ever after and have lots of goods!



THE VERMILION pawn

A Complete Encounter for WFRP

by Ken Rolston

*'Cor! That's a GOOD 'un, that is. Ebr...what is it?'
 'Blazed if I know. But it's sure enough magical. Here...feel it.' (Thrusting the fist-sized object up against the other's cheek.)
 'AHHHGH!' (Leaping backwards in terror). 'It's ALIVE!'
 'No, ya ninny. It's just a rock - I think...'
 'Well, ya better be sure 'fore ya go jammin' it into other folk's faces. Look...(leaning over and whispering)...maybe ya better take it to the Vermilion Pawn. The swine charges an arm and a leg, but from what I hear he's good, ...and discreet.'*

Outline

The Vermilion Pawn and Master Lukas, its proprietor, perform services of vital importance in any WFRP campaign - the identification and evaluation of magic items. Master Lukas is also a source of cash loans for desperate adventurers, though they'll pay high rates of interest, and must leave magical treasure behind as security.

Setting

The encounter may be located in any large town or city in your fantasy campaign - most plausibly in a settlement large enough to have its own college and Magic Guild, because, in his research Lukas must occasionally rely on the larger reference libraries of such institutions.

Reputation

Among the common folk, who have little call to pawn or identify magical treasures, Master Lukas and his establishment are little more than a vague rumour:

'Eh? You've a magical whatsis you want priced? OOH! Let me look...No, no idea who'd you go to. The Guild p'raps, or a banker...the Temple...Oh, there's the Red Pawn or something, that's it, down in the Frieburg...'

Experienced adventurers and arcane students and practitioners know Lukas either from personal experience or direct report:

'Well, there's Lukas at the Vermilion Pawn, and little else to choose. You could take to the Magic Guild, if you're a wizard, and if you're a member, and you know what you're about. Thy've a library there, and maybe you can chivy some old geezer into helping out on the research. But I hear they're none too helpful unless you're well connected, and if you're not a member, well, forget it.'

Course, if you're a man of the faith, you can take it to a temple - though they don't know a lot about sorcery there, and what they do understand, they're likely to requisition - 'for the greater good' or somesuch.

Nope, Lukas is your best bet. Ye gods, his fees are high, but if you need cash, he's got it, and no questions asked. He's awful fast and awful good - too good to be true some say. He's been around for years, so he's got to be reliable - and, as I say, you haven't much choice.'

Appearance and Social Standing

Master Lukas is a pleasant-looking Dwarf of late middle-age, with a slightly protruding belly, an air of scholarly dishevelment, and cheerful, penetrating blue eyes. Lukas has completed the equivalent of an apprenticeship in Alchemy, an advanced career as Scholar, and a Level Two career in Daemonology. He has since moved away from the daemonic arts to resume a career in Wizardry, and despite his involvement in the darker side of magic, a nicer daemon summoner you'd never hope to meet.

As a daemonologist, Lukas has suffered two disabilities, neither particularly disabling. Lukas is allergic to pollen, but he stays away from the countryside, and pollen allergy is not uncommon among normal folk. He has also suffered *Strength Loss* - inconvenient, but hardly crippling.

As a pawnbroker, Lukas is a remarkably agreeable sort. He charges a lot for his services, but so do physicians and other trained professionals. He's an amiable but flint-willed bargainer. He knows he has an effective monopoly in his trade, and doesn't hesitate to remind the client, 'If you don't like my prices, well, where else can you go?'

Lukas is a respected member of the intellectual community. Since he is an expert in magical collectibles, he is especially favoured by rich nobles, who are always trying to wheedle a bit of free advice out of him on what sort of treasures are particularly valuable. He is also a sought-after guest at parties, where an offhand comment from Lukas - 'My, Chancellor, I see you have a set of Janacek Globes.' - prompts the envy and admiration of other aristocratic collectors.

Lukas is quite proud of his dwarven heritage, and makes a concious effort to treat Dwarfs generously in trade and friendship. In fact, his manner toward them is a bit patronising: 'Oh my, yes, we Dwarfs have to stick together, don't we?' However, he is quite at home socialising with human and elven scholars, wizards, nobles, and other professionals.

Dwarven Guards: Lukas employs six dwarven fighters, when he can get them. He outfits them with chainmail and pays them well. Typically, two guard his home in an upper-class section of town (in Middenheim, the Nordgarten district). Two remain at the Vermilion Pawn at all times, while two accompany him as bodyguards on his walks to and from his home, his shop, and on his social visits.

Master Lukas Pfandleiher: Level Two Wizard

M	WS	BS	S	T	W	I	A	Dex	Ld	Int	Cl	WP	Fel
3	52	25	3	5	10	43	1	38	51	67	58	85	32

Skills: Arcane Languages (Daemonic Magick); Astronomy; Brewing; Cartography; Cast Spells (Petty Magic, Battle Magic 1 & 2, Daemonic Battle Magic 1 & 2); Chemistry; Daemon Lore; Evaluate; Herb Lore; History; Identify Plant; Identify Magical Artifact; Identify Unded; Linguistics; Magical Awareness; Magic Sense; Meditation; Night Vision; Numismatics; Read/Write; Rune Lore; Scroll Lore; Secret Language (Classical); Speak Additional Languages (Dark Tongue)

Possessions: Leather jerkin, Short sword, Whistle (to attract the Watch if needed); Amulet of Adamantine (shaped as a daemonic hand - provides T7); Wand of Jet (command is "Have at thee!" with 14 charges remaining).

Magic Points: 18

Alignment: Neutral

Petty Magic Spells: Gift of Tongues, Glowing Light, Open, Protection from Rain, Reinforce Door, Sleep.

Battle Magic 1 (including Daemonic): Aura of Protection, Cause Panic, Mystic Mist, Summon Energy, Zone of Sanctuary.

Six Dwarf Bodyguards

M	WS	BS	S	T	W	I	A	Dex	Ld	Int	Cl	WP	Fel
3	65	22	5	4	9	34	2	20	47	31	52	48	20

Skills: Disarm, Specialist Weapon (Fist), Street Fighting, Strike Mighty Blow, Strike to Stun.

Possessions: Knuckle-dusters, Axe, Sleeved Mail Coat, Mail Coif, Shield, 2D6 GCs.

Lukas's Routine

Lukas keeps irregular work hours - to discourage plotters, he says. Chances of finding him at the shop during daytime is 50%; 10% during the night. The rest of the time he is either at home - where he refuses to see clients, doing research at the Magic Guild or the University, or on social engagements.

When he's at the shop, guards fetch food for Lukas, and in addition several dozen live rats are delivered weekly - most of which are fed to the dogs (but see below).

The Pawnshop

The formidable stone structure squats among shabby old book stores, alchemical wholesalers and other shops of scholarly and antiquarian interest. (In Middenheim, the shop is in the Frieburg, on a nameless alley off the northeast edge of the Great Park). Locating the place is a simple matter of inquiring among the local shopkeepers, or wandering around looking for a stone building with a red chess pawn on the door.

The shop itself is a massive, windowless stone vault, resembling a military blockhouse. The stonework is dwarven, dry-mortared and ponderously secure. The arched stonework of the roof is supported by thick interior walls - 'Bedrock solid!' a Dwarf might remark with satisfaction, 'and as good as you're likely to see above ground.' Built by dwarven stonemasters, the Vermilion Pawn appears to be (and is) more secure than the average bank or prison.



A walk around the building reveals only the front door and a sturdy timber shed with a rear entrance. If Master Lukas is in, two war dogs on disconcertingly long chains are tethered in the back, ever-so-enthusiastically greeting any casual visitors.

During construction, Lukas made filings from worthless cursed magic items, and scattered them in the stonework to confuse magical probing. To *Magical Awareness*, the entire structure radiates magic power.

Front Door: Location 1

This is thick oak, reinforced by iron. A red pawn is painted on the door together with the following notice:

'Knock loudly and wait.'

Lukas scrutinises visitors from the Service Chamber through a concealed wide-angle peep lens. Unless a Daemon or a full regiment threatens, Lukas then releases the locks and bolts.

Booth: Location 2

This narrow room is fitted with a wooden bench for patrons. 'Come in, and close the door behind you, for your own privacy and mine,' Lukas invites, and will proceed no further until the outer door is closed and locked.

Lukas watches patrons through peep holes. If he suspects foul play, he releases Black Lotus powder bombs through a mechanism in the ceiling of the booth. He dumps the first dose, and, if the miscreants seem merely foolish or stupid, he may open the locked door and allow them to escape to warn others against funny business. If his victims appear to be real criminals, he leaves the door locked, dumps a second dose, and sends a guard for the City Watch.

If all is in order, Lukas opens the iron shutters on 2'x2' window between the Service Chamber and the booth. All business is conducted through this window, and at the first sign of trouble, Lukas slams the shutters and pours on the Black Lotus.



KV



Service Chamber: Location 3

Lukas keeps his business records and minor magical trinkets in here, along with a few basic reference texts and analysis tools. These allow him to identify most common potions and devices while the patron waits.

ALL ITEMS MUST BE ANALYSED AND APPRAISED BY LUKAS BEFORE HE WILL EVEN DISCUSS OFFERING A LOAN AGAINST THE ITEM, OR BEFORE CONSIDERING PURCHASE OF THE ITEM.

The procedure is simple. Lukas explains his terms (see below), and if the patron agrees he is charged an initial 10GC for each item to be identified, appraised, pawned or offered for sale. Lukas then withdraws and seals the shutters while he performs basic tests on the items. Note that if Lukas can't identify the object with simple tests, the client still loses the 10GC advance, as Lukas always warns his customers.

If the tests reveal the nature and value of the item, he opens the shutters, and collects the balance for his analysis, before announcing his findings. If the item requires further study and research, Lukas informs the clients and estimates when they should return for the final report.

Patrons interested in purchasing something from Lukas must explain what they seek and how much they are willing to pay before Lukas will reveal whether he has the item in question, or what he will charge for it. Bargaining will affect the sale price in the usual manner.

If the bargaining is successful, the shutters are sealed, Lukas retrieves the object, returns, opens the shutter, and concludes the deal. If Lukas and the client cannot come to terms, Lukas politely asks the client to leave, and closes the shutters. Troublesome clients are assisted from the premises by the guards or, if necessary, the Watch.

Lucas's Business Practices

Pawning Items

Lukas offers 50% of appraised value as a cash loan secured against the item. His terms are 1% interest per day on the loan, with a minimum credit charge of 20GC (to cover the cost of his appraisal).

Thus, if he appraises your Ring of Warding at 500GC, he'll loan you 250GC on the ring. You take the loan and repay it in ten days. At 1% per day, Lukas requires the 250GC loan, plus 25GC interest for 10 days, for a total of 275GC. If you paid it back in one day, you'd only owe 2½GC in interest, but you'd still have to pay the loan (250GC) plus the 20 GC minimum credit charge.

Identifying Items

A flat fee of 20GC + 5% of appraised value is charged for item analysis, with 10GC paid in advance.

His standing offer is, 'If you think my appraised value is too high, I'll buy the object from you for the appraised value. If you think the value is too low, be thankful - your 5% fee is thereby reduced.'

If Lukas can't fully identify the item with his basic analysis test, he offers his Advanced Research services. 'If I can't identify it by mundane methods, you can either take the object to someone else, or pay my advanced research fee: 200GC and 5% of appraised value plus expenses for advanced research.'

Advanced Research takes from 4-6 weeks, with no guarantee of success. However, if Lukas can't identify the item, the client only pays the 10GC basic fee, and is always free to retrieve the item and take it elsewhere for identification.

Identifying Magical Items

In addition to revealing whether or not an item is magical, the skill *Magical Sense* also reveals the number of powers (ie how powerful the item is). To discover just what these powers are, a character with the skill *Identify Magical Artifact* must hold the item, and for each successful **WP** test a single power is revealed. Once the character fails the test he cannot gain any more information.

It is this latter skill that Lukas uses, and the first power learned will always be a general notion of the object's history or function. A *Cure Light Injury* ring, for example, would be identified as a healing ring, or a *Dagger of Death* might be recognized as the work of Mario Fettucini, a Tilean sorcerer formerly employed by the Assassins of the Blade.

With repeated **WP** tests, specific powers (with passwords if applicable), can be obtained. Most items require a specific invocation to activate their magical properties, and since this is generally a security precaution, rarely is the invoking phrase clearly marked on the device.

In addition to these standard methods of investigation, Lukas also has recourse to a vast collection of books and tools which he can use if his *Identify* skill is not sufficient. This reference material and equipment forms the basis of his Advanced Research, and allows him to continue gaining information where he left off: learning everything about an item is extremely difficult for a typical adventurer, but mere child's play for experienced magic hackers like Lukas. Again, Lukas must make a **WP** test to obtain information on each power.

Items with functions purposely or accidentally obscured, and items of inherently obscure function are more serious challenges to magic hackers. Various elaborate research procedures are available, most of which are either time-consuming or dangerous, and none of which guarantee success.

For these very difficult cases, Lukas can always ask his *daemon cabinet* for an appraisal. Lukas generally saves this as a last resort, since the Daemon charges in quarts of humanoid blood. Lukas is a nice fellow, and dislikes such practices, but he is also a practical business man, and will use this resource when all other means have failed.

'Ere! Bob Olley'z dun loadsa Gobboes, an' they're dead good, jus' like 'is uvver stuff! An' Iron Claw minnichers, they're fish'ly appr... er, yer can use 'em in yer WAR'AMMER armies, no trubble! So wotcher waitin' fer! Gerronwivit an' get stompin them Stunties!

IRON CLAW

GOBLINS

1 STANDARD BEARER



2



3



4



5 STANDARD BEARER



6



7



8



9 MUSICIAN



10



11



12 HERO



13



14



15



16



17



18



19



20



21



22



23



24



25



26



27



28



29



30



Designed by Bob Olley
Painted by Citadel Figure Painters

MINIATURES SUPPLIED UNPAINTED

Purchasing Items

Lukas sells items for double their appraised value. On the black market he sells for a lower price, but does a greater volume.

Since it is almost impossible to buy magical items elsewhere, the doubled price is really rather fair - 'Folk looking for a specific item are happy to pay, and folk who complain about the prices have no business shopping in the first place.'

The following magical items are for sale, and are stored on shelves behind the curtain, out of sight of the clients. Lukas's appraised value and his asking price are listed after each item. Lukas honestly represents the true capabilities of the items to his clients - a policy he steadfastly adheres to. (For details of magical functions refer to **WFRP** pp183-190.) More expensive items are available to the right sort of people, but Lukas keeps these secure in a special cabinet (see below).

Lukas may accept less than his asking price, but never less than the appraised value. Factors inclining Lukas to accept a lower price are package deals or a successful use of *Bargain*. Obvious experts in magic gain +10% to the *Bargain* test out of professional respect. None of the following are particularly remarkable or valuable as collector's items.

Items for Sale

Ring of Gift of Tongues: 2 magic points remaining. Invoke with 'Speak and Be Known to Me.' (120GC/240GC)

Ring of Magic Lock: 9 magic points remaining. Invoke with 'Bar to Mine Enemy.' (190/380GC)

Ring of Cure Light Injury: 10 magic points remaining. Invoke with 'In Shallya's Name.' (200GC/400GC)

Ring of Cure Light Injury: 6 magic points remaining. Invoke with 'The blessing of Shallya on this one, who comes in humble supplication.' (160GC/320GC)

Ring of Cure Light Injury: 2 magic points remaining. Invoke with 'In Ulric's name, heal this warrior.' (120GC/240GC)

Ring of Protection Against Chaos: 10 magic points remaining. When invoked by the phrase, 'Chaos Avert! In Solkan's Name!' a magic point is expended, and protection lasts for 7 rounds. (200GC/400GC)

Ring of Protection Against Chaos: 6 magic points remaining. When invoked by the phrase, 'Death to Chaos!' a magic point is expended, and protection lasts for 7 rounds. (160GC/320GC)

Ring of Protection Against Chaos: 5 magic points remaining. When invoked by the phrase, 'By the Hammer of Sigmar, Blast Ye, Chaos Fiend!' a magic point is expended, and protection lasts for 7 rounds. (150GC/300GC)

Knight's Helm + 1: in battered condition. (100GC/200GC)

Sword of Protection: +1 AP to all body areas, 10 magic points. When invoked by the phrase, 'Ward mine enemies!' a magic point is expended, and protection lasts for 2D6 rounds. (300GC/600GC)

Sword of Fear: 5 magic points. When invoked by the phrase 'Yield or die!' a magic point is expended, and protection lasts for 2D6 rounds. (200GC/400GC)

Dagger of Death: +2 damage, 6 magic points. No command word but with each successful attack, a magic point is expended, and the additional damage is inflicted. (400GC/800GC)

Mace of Sleep: 4 magic points. Invoke with 'Sweet dreams', a magic point is expended, and victim struck makes a Magic test at -30 penalty or falls asleep for 2D6 turns (300GC/600GC)

Spear Head of Undead Bane: 7 magic points. Invoke with 'Serve Morr and die, undead!' a magic point is expended, and bane effect lasts for 10 rounds.(170GC/340GC)

The Lab: Location 4

Here Lukas does most of his Advanced Research. His client services take up only as small portion of his time. The remainder is spent on personal projects - magical studies or researching items he has purchased for his own collection.

The Magic Guild itself does not have such a fine collection of magical references pertinent to Lukas's trade. The value of the reference works and tools alone is over 8000GC. (I'd love to list each title and tool, but we're running a bit long here. If the player characters get into the lab and start asking embarrassing questions about Lukas's equipment, I'm sorry, but you're on your own.)

Magical items of great value or interest are stored inside what appears to be a metal cabinet. This is in fact, a Lesser Daemon, bound into the form of a cabinet, and sworn to serve Lukas for 1001 years. The Daemon is intelligent, can speak and is incredibly vicious. It can form thousands of tiny toothy mouths, each of which delivers a serpent's poisonous bite. Lukas feeds it a live rat daily - a rather discouraging experience for the rat, you can be sure.

KW



Sikinnes - the Daemon Cabinet

Sikinnes normally keeps his mouths shut, as ordered by his master. However, if someone touches him without Lukas's consent, Sikiinnes gleefully forms 1D6 mouths and chews on the improvident victim, automatically delivering 1D6 bites at S1, each with the additional effect of *adder root* (see **WFRP** p82). Unable to contain this amusement, Sikiinnes then chatters like a magpie, gloating over his triumphant attack, mocking the probably-dying victim, and generally making a nuisance of himself.

Life as a cabinet is not such a hardship for Sikiinnes. 'Try a couple of aeons as a Lesser Daemon sometime, and see how you like it,' he observes. 'The Greater Daemons stand around all day and kick molten rock and ectoplasmic slime on you. No fun, believe you me.'

In his cabinet form, Sikiinnes doesn't cause *fear*, nor is he subject to *instability*. If he takes damage from any physical or magical attack, the spell binding him as a cabinet is disrupted, and he is free to attack as a Lesser Daemon. (It's a good thing Sikiinnes doesn't know this; he'd probably goad the PCs into attacking him.)

Contents of the Cabinet

In the cabinet are four items for sale, all quite valuable but fairly unremarkable. Note that the values listed are for collectors; no sensible adventurer would ever consider paying such prices. Two other items are not for sale, neither are particularly valuable, but both are distinctly remarkable.

Boots of Gucci: 3 magic points. When invoked with 'Grace is beyond style.' in Tilean, a magic point is expended, and the wearer receives a +40 bonus to *Fellowship* as long as the boots remain on the feet. Primarily of interest to collectors, for Gucci is an enchanter of wide renown. (8,000GC/16,000GC)

The Sword of Tain-Ella: 0 magic points. The secrets of recharging this elven sword, as well as the function of the device are lost, but the sword retains its enchantment. Tain-ella is recorded as a Sea Elven merchant prince of late 23rd Century. A collector's item. (1500GC/3000GC)

The Hand of Hardarin: a Wand of Jet in the form of an ebony staff with a carved fist at the top. Currently it will only function when invoked by Hardarin - dead for 75 years. The command phrase could be altered by a master enchanter, but it would destroy the collectible value of the item. (5,000GC/10,000GC)

The Rod of the Fifth Part: an ancient device of obscure origin and function, but has a wide reputation in folklore as a staff of great power if the other parts were assembled. At present, no more than a fabulously-expensive curiosity. (10,000GC/20,000GC)

Not for Sale

A badly battered miniature suit of armour for a humanoid two inches tall, engraved with three power runes, none of which have been identified by Lukas. Origin, function, and value unknown.

A gold-plated Fimir skull. Lukas has identified it from ancient chronicles as a decoration from a Fimir battle standard, but has been unable to determine any details of the object's function. Value unknown.



Rear Vestibule: Location 5

When Lukas is not present, two war dogs are here, unchained. Otherwise, they are chained outside the rear entrance.

Any attempt to open the false door causes a triple dose of Black Lotus bombs to drop from a concealed trap door in the ceiling. Between two stones to the left of the false door at knee height is the release catch for the secret door. A thin object three inches long must be inserted between the stones and pressed down in order to release the catch, which then remains open for one round - just time enough to step to the secret door and go through. However, pressing the catch does not reveal the location of the secret door, so those clever enough to find it will probably assume it opens the false door - heh heh!

Guard Room: Location 6

When Lukas is not present, two guards sit here and take turns napping. When Lukas is present, his personal bodyguards take over, permitting the regular guards to run errands or take time off. (Lukas is a gracious and generous employer.)

Both Lukas and the guards on duty have keys to the sturdy locks on the rear entrance. Only Lukas has the key to the locks on the door from the guard room to the rear vestibule.

Additional Security Measures

Player characters contemplating breaking and entry upon The Vermilion Pawn should be permitted an *Intelligence* test to anticipate the following deterrents, or may be informed of such by local criminals, at your discretion.

Lukas has designed elaborate precautions to protect his lab and his wares, but he knows that making his

shop a fortress is not sufficient to discourage the dedicated thief. Therefore he pays a substantial protection fee to the prominent racketeering bosses of the city. No sensible local thief would think of encroaching on the territory of these powerful crime bosses.

Further, Lukas has powerful friends in the Magic Guild who would be happy to help him track down anyone who violated his privacy or ransacked his magical treasures and research facilities. Consequently, Lukas would not risk his life in defence of his shop, confident that he could pursue thieves later and wreak a terrible vengeance upon them.

06
WHIRLWIND



CHAOS DWARF
WAR MACHINES

Cast out by his own kind, the Dwarf Engineer Thymbrin Snakebeard turned to Chaos. Now he designs and manufactures devastating war machines for Chaos armies, crewed by the ferocious and powerful Chaos Dwarf Boar Centaurs which he has bred specially for this purpose.

Two of his creations, the Whirlwind and the Tenderiser, have been recreated in miniature by the short but spiky Mike Perry.



07
TENDERISER



ORC
CROSSBOWS

Dead good, these crossbows. An' jus' coz the Stunties use 'em don't mean we can't. S'grate - yer can stick a Stunty miles away. An' why should them Gobbo bowboyz 'ave all the fun? That Kevin Adams come up wiv the goods again - loadsa crossbow boyz f'yer War'ammer army - all wiv them new plastic crossbowz, an' all.

BLOOD BOWL

A successful Blood Bowl team needs a good offence and a good defence, and these two can provide that vital extra power in either role. The Ogre player, designed by Jes Goodwin, and the Troll player, designed by Mike Perry, are practically guaranteed to improve your team's touchdown averages and kill ratios - and the transfer fee is a lot less than you might expect.



OGRE



TROLL

Models supplied unpainted



KW

Sikinnes - Lesser Daemon

M	WS	BS	S	T	W	I	A	Dex	Ld	Int	Cl	WP	Fel
4	50	42	4	5	12	60	2	89	89	89	89	89	14

In unbound form Sikinnes appears much like a traditional Daemon, but with a very long tongue that flicks around with lightning speed. His bite attack is poisonous, and as with the Daemon's bound form, has the effect of *adder root*.

This unique Daemon also has the skill *Identify Magical Artifact*, and is allowed as many attempts at discovering powers as he has quarts of blood: failure to make the WP roll does not preclude further effort, and only a highly protected item will be immune from the monster's probings. Since changing from Daemonologist, Lukas has used this power rarely.

Two Wardogs

M	WS	BS	S	T	W	I	A	Dex	Ld	Int	Cl	WP	Fel
6	41	0	3	3	7	30	1	-	43	14	43	43	-

Both are trained only to accept food from Lukas.

Adventure Hooks

1. A valuable magical item is stolen from the player characters, or from a patron or cult of the PCs. It is suggested that they approach Lukas and enlist his aid, anticipating that the thieves may try to pawn the purloined magical item at his shop.
2. A master sorcerer with a unique *teleport booth* enlists the aid of the PCs. 'A fellow has a fine pair of magical boots I want. I'll teleport you inside his lab, right past all his defences, and all you have to do is find the boots. I'll give you one hour, then I'll teleport you right out. Safe as houses.'
3. Lukas gets a wind of a plot to break into to his lab. He hires the PCs as extra guards, though as he says 'I doubt I'll need much help, I can take care of myself.'

Pride cometh before a fall. Four Chaos mutants enter the patron's parlor. One with incredible strength rips the iron shutters aside before the Black Lotus takes effect. The PCs, sitting in the guard room, hear a shriek and a sound of rending metal shutters.

Now what? Lukas has not seen fit to reveal the security secrets of his lab to his temporary employees. Lukas managed to open the front door before he was bashed unconscious. Now the mutants, still groggy from the Black Lotus, are loose inside the lab.

4. A squadron of pixies threaten to set up housekeeping with the PCs unless aided in recovering a precious pixie ancestral treasure from Lukas's shop. (Sure, pixie armor. See above if don't believe me.) 'Don't worry, humans,' the pixies squeak, 'we'll help you with our marvelous magical powers!'

With a dozen pixies armed with hair-brained schemes concealed in their shirtsleeves, our heroes more or less confidently enter Lukas's front door...

Campaign Tip: Magical Items

The magical items listed for sale embody my two basic principles of the Ideal Fantasy Magic Item:

Colourful Detail: The invoking phrases and curious histories, for example, give the items a little personality. Without this approach, magic items are generic shotguns in their fantasy contexts.

Limited Power and Uses: Important for two reasons - first, because it keeps the campaign's Magic Quotient under the GM's control, and second because invoking an item with limited 'charges' is a significant tactical decision, developing prudent applications of a scarce resource.

A Final Note

My one regret about The Vermilion Pawn is that Sikinnes the Daemon Cabinet is in a place where no PC is ever likely to encounter him. Perfectly plausible, and a great relief to the PC, no doubt, but it seems a shame to waste so charming a little nasty. So maybe lots of sorcerers, Chaos baddies, and rich, evil folk have cabinets like Sikinnes lying around where PC burglars can find them.

Or maybe you want to leave one lying around in the street somewhere.

You're welcome.

THE VERMILION PAWN

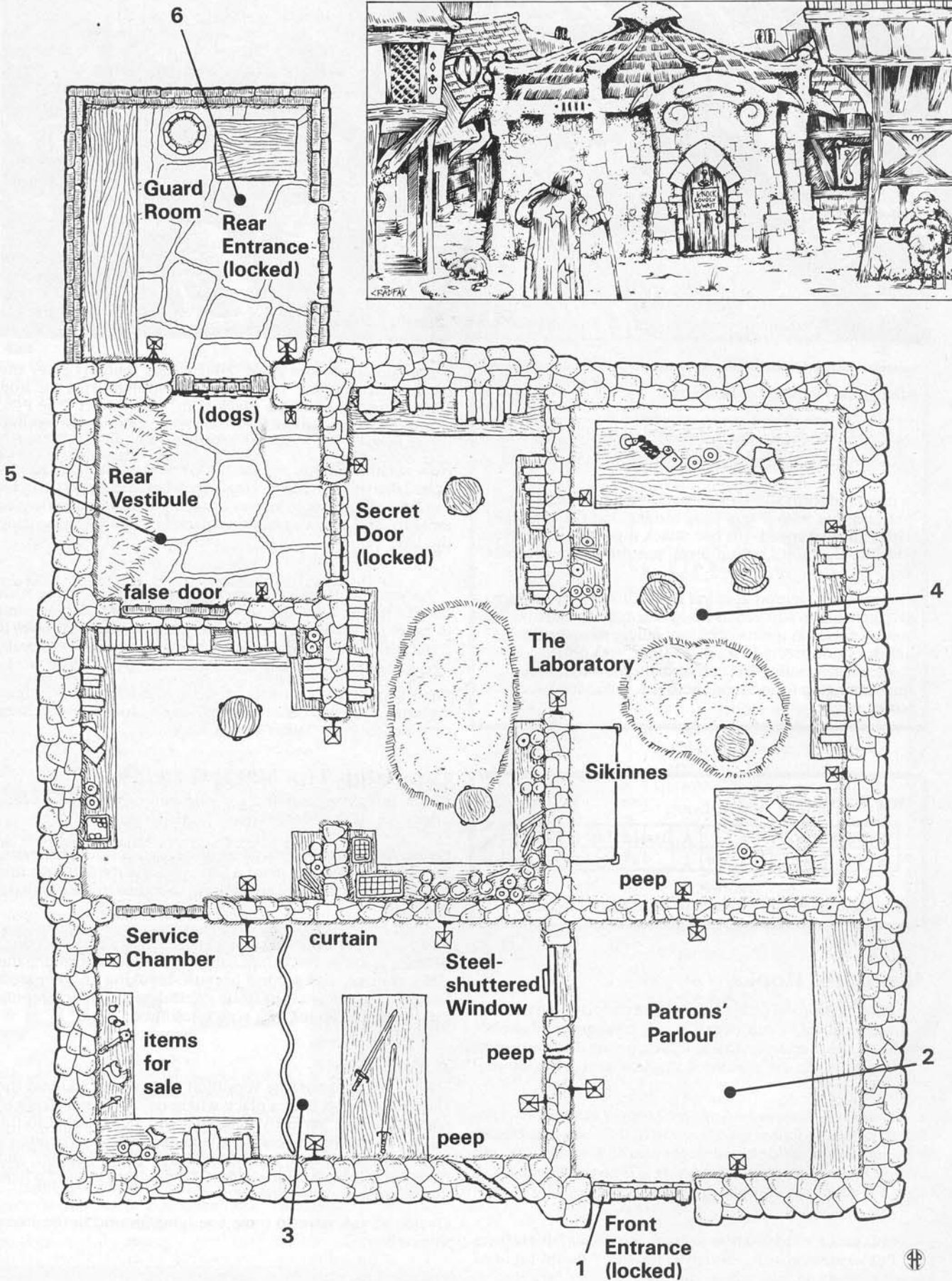



On the Beach

In other periodicals you often see, instead of a regular columnist, the words "Fred Bloggs is on holiday". This may mean "we've sacked him", or "he was too drunk to write this week's piece", or "He sent it on a computer which we accidentally wiped", or "if we'd printed it, Maxwell would have sued", or even, sometimes, "Fred Bloggs is on holiday". I'm on holiday myself, but after a day of building sandcastles I haul out a portable computer and write furtive reviews... Are you going to admire my dedication? I thought not.

Half a Glass of Moonshine by Graham Sunstan Martin (Unwin 179pp £11.95) is the fourth adult novel by a writer who's been getting consistently better since I allotted faint praise to this first, *The Soul Master*. This latest is one of the few intelligent books whose mainspring is the "paranormal", having not only a good story with nifty characters but a background of intelligent theory. Its closest theoretical rival is Ian Watson's bizarre *Miracle Visitors*, which tackles the problem of inexplicability and irreproducibility with arguments from mathematical logic - our universe, as Godel's theory shows for complex formal systems, contains unprovable truths. Martin's best-articulated approach is neurological, a matter of perception: our universe may contain truths which for excellent Darwinian reasons aren't usefully detectable. Examples are given: *Moonshine's* cheekily Carrollian and Tolkienian chapter-headings conceal several rabbit-punches, most effectively when the amiable craziness of the Mad Gardener's Song (*Sylvie & Bruno*) evokes a nightmare case-history from the pages of Dr Oliver Sacks. Initially slow-moving and thrifty with its fantastic *frissons*, the book takes the well-drawn heroine Kirsty on journeys outside rationality to a conclusion as satisfying as the rules allow - depending on the angle of your question, the final answer is (a) a life-saving justification of everything that's gone before, or (b) a lemon. I enjoyed this one hugely.

Moonshine has been given Unwin Hyman's new "posh" look, apparently reserved for work not easily forced into genre pigeonholes. It's a striking design: broad white bands above and below a central picture whose dominant colour is picked up in the initial letters of the title. In the same format are two good short story collections, Garry Kilworth's *The Songbirds of Pain* (187pp £2.95) and M John Harrison's *The Ice Monkey* (144pp £2.95). Kilworth is a highly effective short-story writer with a particular gift for exotic locales and nerve-tingling insights.

Harrison's main theme here is top class kitchen sink fantasy, inner-city sleaze with ambiguously nasty implications; in *Ice Monkey*, the individually fine stories add up a little oppressively, and outdoor pauses are needed to clear one's head of the metaphysical stench.

Gollancz indicate their front-runner books with colour covers (to the discomfort of authors who only ever get the grotty standard design); one such is Greg Benford's *Great Sky River* (326pp £11.95). This features electronically enhanced humans pursued by inimical machine intelligence across a dying world near the central black hole into which our galaxy is gurgling like bathwater: ambitious stuff, conscientiously worked out, and I wish I could enjoy it more. Benford's future people are such dim and unsympathetic hicks, so lumpish in their slang and so wilfully determined not to use the wisdom of the ages built into their augmented memory banks, that the pursuing "Mantis" machine deserves to win. This is theoretically a good book, but something's gone wrong in the execution: the skilled imaginings (think of a vast electromagnetic intelligence anchored in and powered by the black hole's stormy accretion disc) can barely fight their way through meticulous but uninspiring prose.

By contrast, though Garry Kilworth has little new to say in *Cloudrock* (Unwin 160pp £11.95), and his low-tech tribes are shackled by still less defensible practices like ritual cannibalism and incest, the colourful story exceeds its modest ambitions and - in a word - works. This closed environment tale of a jungle in the sky gains power not from scientific thinking (the set-up is just barely plausible) but from psychological and anthropological conviction. Oddly enough, Kilworth's primitives sound both more convincing and more literate than Benford's enhanced folk: their difference is conveyed through omissions and tone of voice, rather than a mass of jargon.

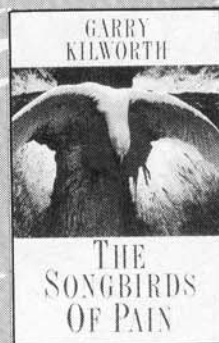

Michael Scott Rohan and Terry Pratchett continue their fantasy sagas with the "Winter of the World" conclusion, *The Hammer of the Sun* (Macdonald 502pp £11.95), and the fifth Discworld farce, *Sourcery* (Gollancz 243pp £10.95). Rohan's trilogy is well above average, marred only by sluggish transitions involving rather too many words: as soon as our Mastersmith hero settles down to his forge again, the inventiveness is compelling. Having previously sussed carbon fibres and electroplating, he now goes on to invent weather control, Greek fire, distillation, napalm, powered flight and the solar furnace, while casting impressive mythic shadows as crippled Vulcan and, later, Thor. As for the Hammer of the Sun

itself, the final masterstroke against the Powers which plan an eternal ice age... it's so outrageous that Rohan hints at its full nature only indirectly.

Sourcery (sic) is also outrageous, if a fraction less triffic than it's predecessor *Mort*. I'd describe it, but I don't think your feeble minds could withstand being told of a magical disaster so appalling that even the bedbugs flee Unseen University, taking their mattress homes with them; of the horse theft resulting in One Horseman and Three Pedestrians of the Apocalypse (we also discover Pestilence's favourite tippie, a small egg nog with a cherry in it); of verse rewrites to make Omar Khayyam rotate at 15000 rpm in his grave; of eldritch footnotes and abominable puns beyond the grasp of sanity ... All right, read it; don't say you weren't warned.

The Misenchanted Sword by Lawrence Watt-Evans (Grafton 332pp £2.95) is an absolutely bog-standard fantasy novel. In a haze of magical absolutism and spell levels suggesting a heavy RPG influence, our hero acquires a charmed/cursed sword which preserves him from death and when drawn the first 100 times gives him an infallible kill, but (isn't there always a But? isn't it always ridiculously arbitrary?) will then smite *him* and give the next user 99 sure kills until (pow!) the one after that gets 98... This "countdown" plot device resembles Robert Louis Stevenson's "The Bottle Imp", which was satisfyingly concluded in about 30 pages. Watt-Evans takes 332 pages to avoid any exploration of the long-term events he's set up. For a while it does seem that he's going to tackle seriously the hero's Tithonus problem (the sword keeps him alive, not young), but all is solved by a second and not even hard-won dose of magic, a conclusion which is unsatisfying and flabby. Inoffensive; instantly forgettable.

Slow Fall to Dawn by Stephen Leigh (Headline 165pp £2.50) is a first novel; worthy but slightly overwrought SF with distant echoes of Frank Herbert, eg much mental debate (here kept to a reasonable level), a feudal, Guild-based future society, and unlikely excuses for swashbuckling swords and daggers when lasers and sonic weapons exist. The action centres on an Assassins' Guild which sportingly rigs the odds so 15% of contracted victims scape (it seems less sporting for them to require payment for failures). When a politically important kill joins the 15%, the Guild's essential neutrality is called into question, and the story takes off from there. I boggled on finding that not one of these frightfully honourable people questions the morality of assassination, and became altogether incredulous when this obscure planet's offworld embassy starts talking turkey with the assassins, like a British Raj civil servant giving serious consideration to the officially sanctioned export of Thuggee to Victorian England. Leigh writes well but not quite convincingly.

Lastly, a worthy reissue: **The Intrepid Enchanter** by L Sprague de Camp and Fletcher Pratt collects all their humorous fantasies about Harold Shea, the incautious academic who travels to fictional worlds via "syllogismobile" to mess up the action of Norse, chivalric, Finnish and Irish myth. Neither author achieved quite this light touch when working alone. If I had a collaborator, maybe we'd think of a witty conclusion for this column, but instead I'll just note that the cover - Ian Miller's quirky steel engraving style - is a welcome change from facile airbrushed grot.

IN THE BEGINNING - OR MAYBE
A BIT BEFORE THAT...



...THERE WAS THE WATCHER...



© CARL CRITCHLOW '88

...SINCE THE VERY FIRST MORNING
OF CREATION HE HAS SAT ATOP
LOFTY MOUNT EREGOR, DOING
WHAT HE DOES BEST...



...WATCHING!!

THE LITTLE BARB

STORY - MARC GASCOIGNE
ART - CARL CRITCHLOW

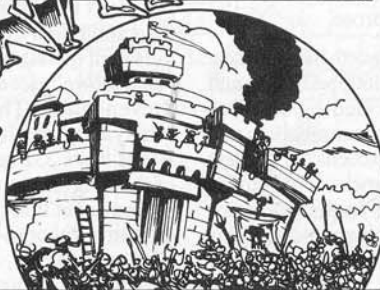

THROUGH LENSES OF PURE POLISHED
DIAMOND FROM BEYOND THE WILDEST DREAMS
OF THE MOST DEMENTED JEWELLER, HIS
UNBLINKING EYE SEES ALL.



FROM THE INNER SANCTUMS OF THE
MOST OPULENT PALACES TO THE SLEAZIEST
BACK STREET TAVERN...



HIS PRICELESS GOLDEN TELESCOPE
LETS HIM GAZE UPON THE MOST
DISTANT OBJECTS AND EVENTS.



CONSTRUCTED BY THE GODS BEFORE
TIME BEGAN THE WATCHERS REJEWELLED
EYE GLASS MISSES NOTHING



NO-ONE KNOWS THEY ARE BEING WATCHED
OR EVEN GUESSES AT THE WATCHER'S
IMMORTAL SCRUTINY...



...THEN AGAIN...



...PERHAPS THEY DO!

WHAT'S YOUR PROBLEM
PAL?



ERR...!



I WAS ALWAYS TAUGHT
THAT IT'S RUDE TO
STARE!

I WAS ALWAYS TAUGHT
THAT IT'S RUDE TO SMASH
PEOPLE OVER THE HEAD WITH
TELESCOPES - BUT THERE
YOU GO!

PIRATES



PLANETARY RAIDERS, WORLD-BURNERS, SPACEWAY SCUM... CALL 'EM WHAT YOU LIKE THEY'RE ALL THE SAME - ALL DIRTY ROTTEN PIRATES! STAMP ON ONE NEST AND ANOTHER SPRINGS UP, BUT DEEPER, DARKER, BETTER HIDDEN. IT IS BITTERLY IRONIC THAT THERE IS NO SHARPER THORN IN THE SIDE OF THE IMPERIUM THAN ITS OWN KIND GONE BAD.



DESIGNED BY BOB NAISMITH AND MIKE PERRY

WARNING: THIS PRODUCT CONTAINS LEAD WHICH MAY BE HARMFUL IF CHEWED OR SWALLOWED. CITADEL MINIATURES ARE NOT RECOMMENDED FOR CHILDREN UNDER 12 YEARS OF AGE

COPYRIGHT © 1988 GAMES WORKSHOP. ALL RIGHTS RESERVED.

Models Supplied Unpainted

CHAPTER APPROVED

INTRODUCTION

Following the revised Dreadnought rules in WD100, many readers have asked for vehicles to be given a similar treatment. As with the Dreadnoughts in the WH40K book, the vehicle rules were designed to be generic so that gamers could field their own conversions and scratch-built models. However, now that Citadel produce a range of vehicles, with more on the way (including the much awaited *Rhino*, see pp51-54), it seems appropriate to overhaul the existing material.

These new rules are intended to make vehicles more effective on the battlefield. Their survivability has been increased by the common use of power fields and power field synchronisers adapted from the Dreadnought rules. In addition, they can now carry far more equipment and weaponry, putting them on a new plane of effectiveness. Although I anticipate most players welcoming these changes, they are by no means compulsory. Players may opt to use only sections of the new rules, depending on the scale of battle being fought.

TURNING

The turning rules don't change but let's go through them here to make sure everybody's clear on how the system works.

A vehicle with a move of, for instance, 10" can turn either left or right throughout any portion of its movement. For example, it could move straight ahead 3", turn left through 3", move straight ahead a further 2" and turn right 2". The total distance moved is 10". Any combination of turns and straight movement is permitted, so long as the total equals the vehicle's movement distance. Players are recommended to stick to whole inches.

When moving forward simply measure directly to the vehicle's front. To make a turn to the left or right, move the vehicle so that its path describes an arc.

The vehicle makes a turn to the left or right.

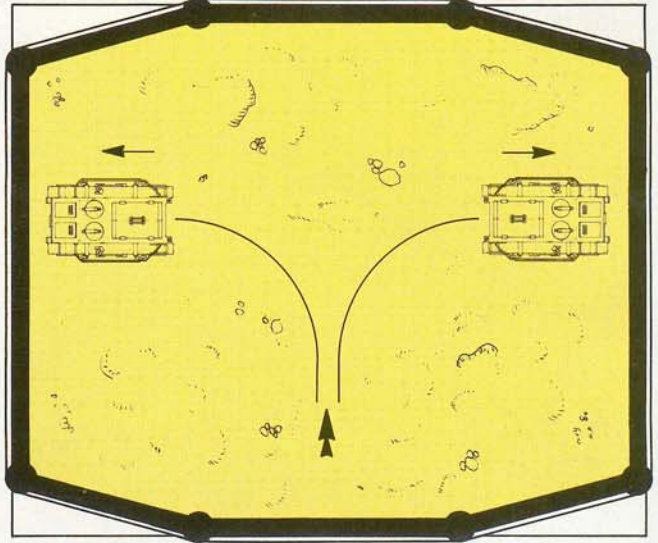

Weigh the fist that strikes men down
And salutes the battle won.

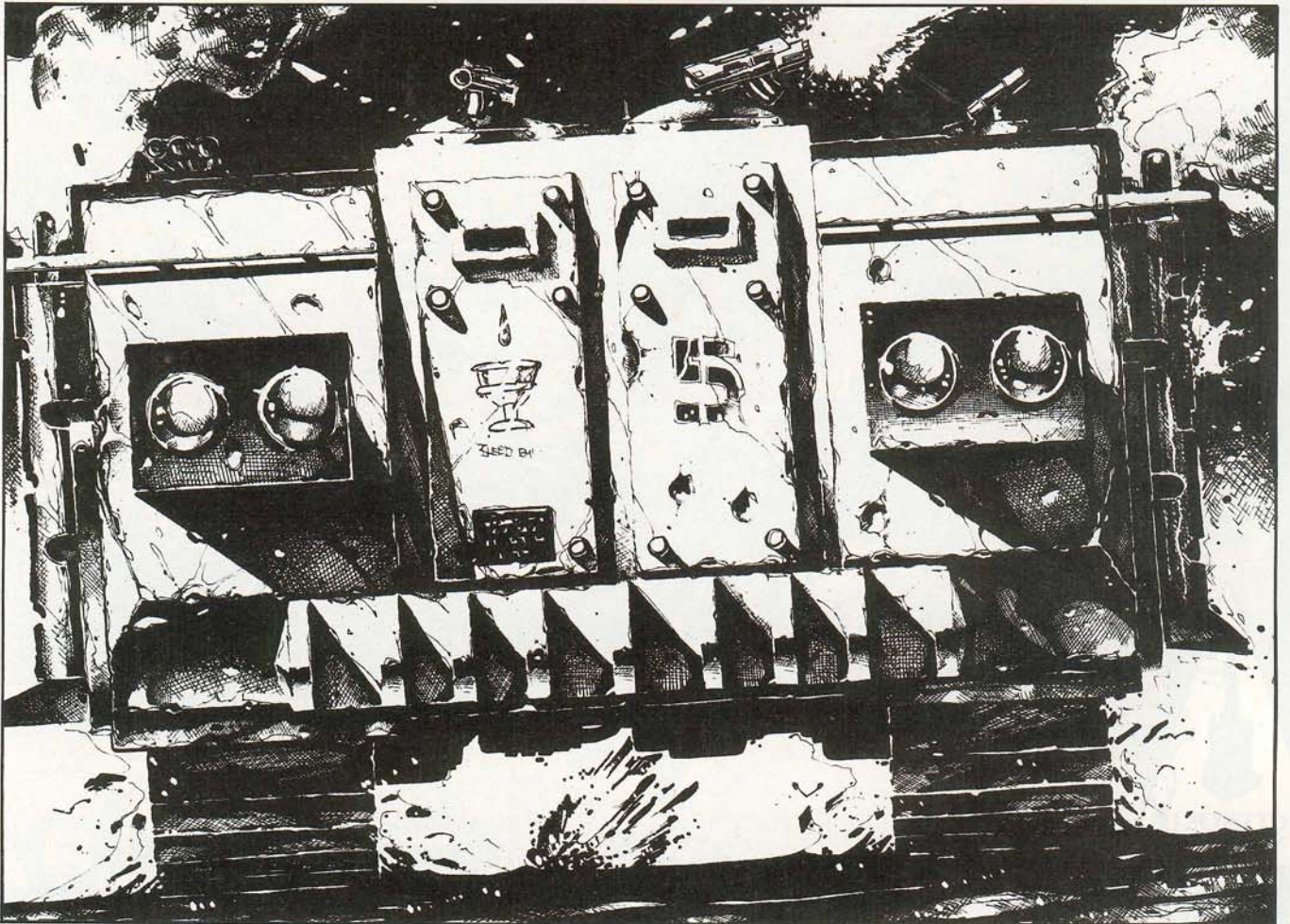

Most vehicles move along an arc which has a radius equal to their total movement that phase. For example, a vehicle moving 10" travels along an arc with a radius of 10".

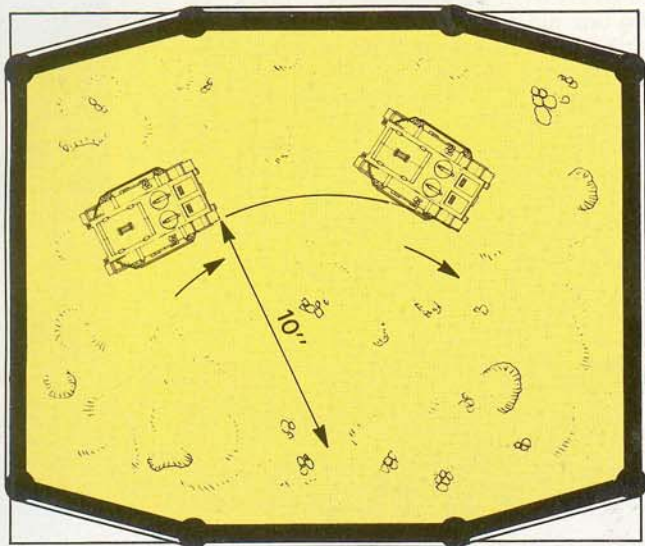

To measure this arc use a tape measure. Extend it to the required length and place it at right angles to the vehicle's front.

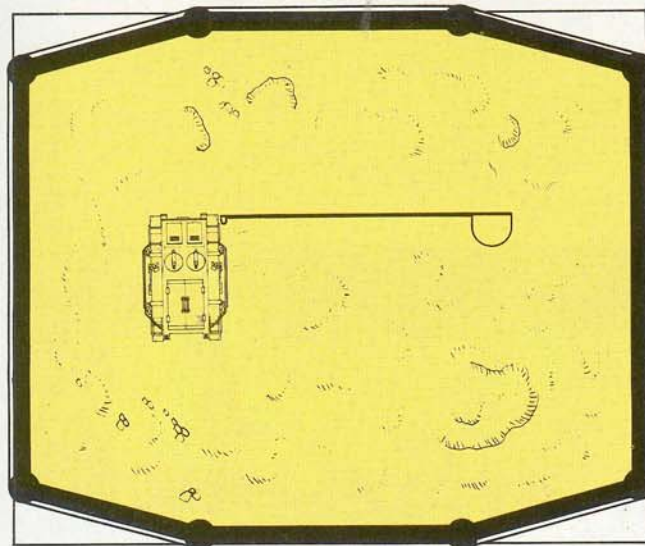

Now pivot the tape describing the arc, swivelling the end of the tape to the place where you want the turn to end.

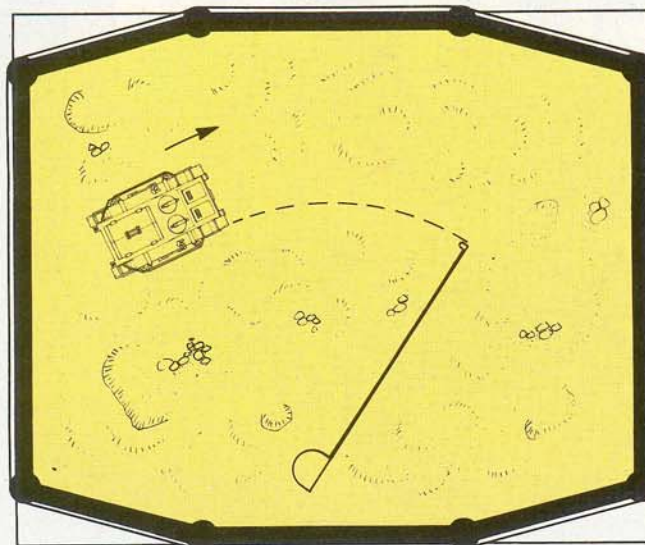

Now move the vehicle into position.

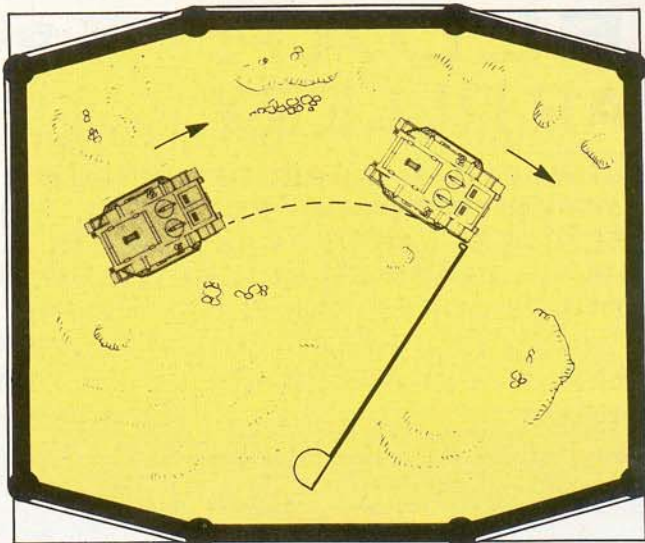

Now measure to the original position and adjust the vehicle back or forward if required. Don't worry about measuring exactly along the arc as it is easy to get a reasonably accurate measurement, which is good enough for our purposes.

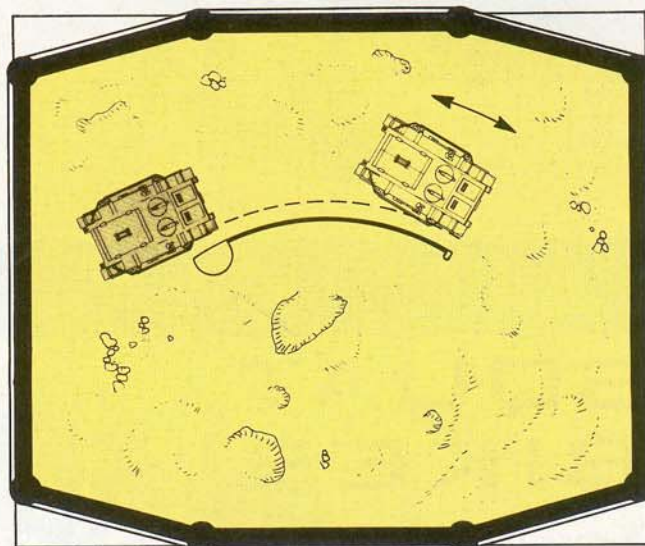

Some vehicles have a *turn radius ratio* of either $\frac{1}{2}$, 2 or 3. This means that the radius of the arc equals not the total movement that phase, but the total movement multiplied by the TRR. Most vehicles however, have a TRR of 1 and turn exactly as described above.

The system accurately represents the manner in which vehicles turn, linking speed directly to their ability to corner. A slow-moving vehicle can turn a very tight corner; a vehicle travelling fast will inevitably describe a larger turning arc. Any vehicle is allowed to use an arc greater than its current movement if the player wishes. Vehicles with a TRR of $\frac{1}{2}$ (such as bikes) are very nimble, and can turn tightly whilst travelling at considerable speed. Other vehicles are cumbersome, and have a TRR that reflects their lack of manoeuvrability.

Turning On The Spot

A stationary bike may be turned on the spot to face any direction. It is also possible to turn any tracked vehicle or hoverer in the same manner, but the vehicle may only be turned within 90° of its original direction.

Moving Backwards

Restrict the maximum speed so that it is the same as the vehicle's acc/dec.

ELDAR ARTILLERY

NEW ELDAR RAPID-DEPLOYMENT WEAPONS TEAMS! FEATURING THE SCATTER LASER, LAS-CANNON AND HEAVY PLASMA GUN TOGETHER WITH INDIVIDUAL CREW FIGURES. SUPPLIED IN RANDOM PACKS OF TWO WEAPONS, EACH WITH ITS OWN CREW FIGURE AND MOBILE SUSPENSOR PLATFORM.

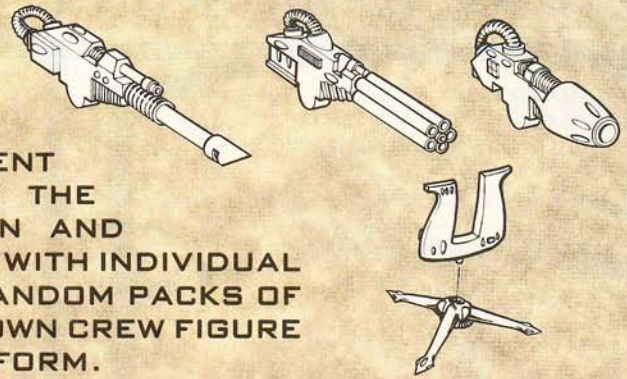

DESIGNED BY JES GOODWIN

SQUAT BIKES

A SPECIAL MULTI-PART MODEL, CONSISTING OF RIDER ON EITHER A BIKE OR TRIKE MACHINE, PLUS VARIABLE FRONT WEAPON/HEAD-LAMP MOUNTING. LONE BIKE GANGS, IMPERIAL GUARD OUTRIDERS, AND ANY NUMBER OF SPECIAL FORCES CAN BE ASSEMBLED USING THIS MULTI-CHOICE SYSTEM.

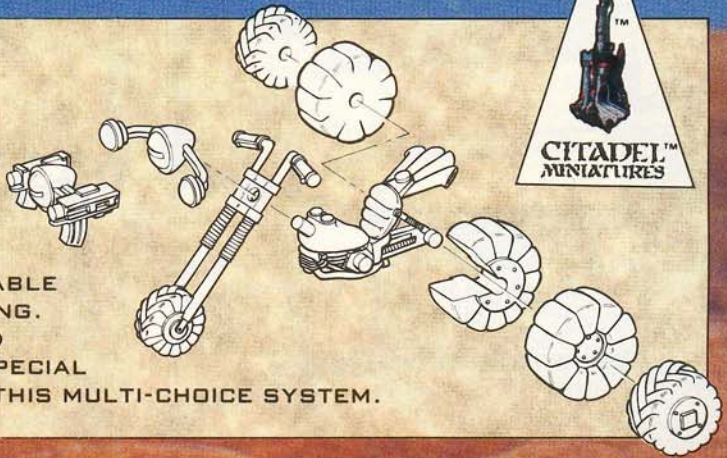

DESIGNED BY THE PERRY TWINS

Models Supplied Unpainted

COLLISIONS AGAINST CREATURES

The existing rules make it rather too easy to suffer damage when attempting to run down fleeing Gretchin and other unfortunates with large, heavy vehicles. To rectify this, vehicles *never* suffer damage as a result of hitting a normal creature if the vehicle's *toughness* is two or more greater than the creature's *toughness*. Otherwise the rules on page 40 of *Warhammer 40,000* apply.

The greatest man is but a ripple on the surface of space

EQUIPMENT STOWAGE

The current stowage rules allow little equipment to be carried. As we shall be introducing new equipment, this figure (Eq) should be doubled for all vehicles and random generation statistics in **WK40K** and **Chapter Approved**: note - we have already incorporated this change in the *Rhino's* statistics. For example, a standard, heavy tracked vehicle now has 12 points of equipment rather than 6, and a randomly generated tracked vehicle will have 2D6 points of equipment rather than D6.

Speed the bolt that brings the end
Of enemy and friend.

WEAPON POINTS

Similarly, the amount of weaponry a vehicle can carry should be doubled. The new extended random chart for weapon generation is given below.

Weapon points																								
D6	1	2	3	4	5	6	7	8	9	10*	11	12	13	14	15	16	17	18	19	20	21	22	23	24
1	1b	2b	3b	4b	5b	6b	7b	8b	9b	10b	11b	12b	13b	14b	15b	16b	17b	18b	19b	20b	21b	22b	23b	24b
2	1b	2b	1b1h	2b1h	3b1h	4b1h	3b2h	4b2h	3b3h	4b3h	3b4h	4b4h	3b5h	4b5h	3b6h	4b6h	3b7h	4b7h	3b8h	4b8h	3b9h	4b9h	3b10h	4b10h
3	1b	2b	1b1h	2b1h	1b2h	2b2h	1b3h	2b3h	1b4h	2b4h	1b5h	2b5h	1b6h	2b6h	1b7h	2b7h	1b8h	2b8h	1b9h	2b9h	1b10h	2b10h	1b11h	2b11h
4	1b	2b	1b1h	2h	1b2h	3h	1b3h	4h	1b4h	5h	1b5h	6h	1b6h	7h	1b7h	8h	1b8h	9h	1b9h	10h	1b10h	11h	1b11h	12h
5	1b	1h	1b1h	2h	1b2h	1v	1b1v	2b1v	1b1h1v	2h1v	1b2h1v	3h1v	1b3h1v	4h1v	1b4h1v	5h1v	1b5h1v	6h1v	1b6h1v	7h1v	1b7h1v	8h1v	1b8h1v	9h1v
6	1b	1h	1b1h	2h	1b2h	1v	1b1v	1h1v	1b1h1v	2h1v	1b2h1v	2v	1b2v	1h2v	1b1h2v	2h2v	1b2h2v	3v	1b3v	1h3v	1b1h3v	2h3v	1b2h3v	4v

b = basic weapon, h = heavy weapon, v = very heavy weapon. A vehicle with 10 or more weapon points may install a Defence Laser if it generates a very heavy weapon. However, Defence Lasers occupy 10 rather than 6 weapon points, so other weaponry must be subtracted to compensate for this. One way of doing this is to deduct 10 points for the Defence Laser and re-roll any remaining points randomly. No vehicle may have more than 1 Defence Laser.

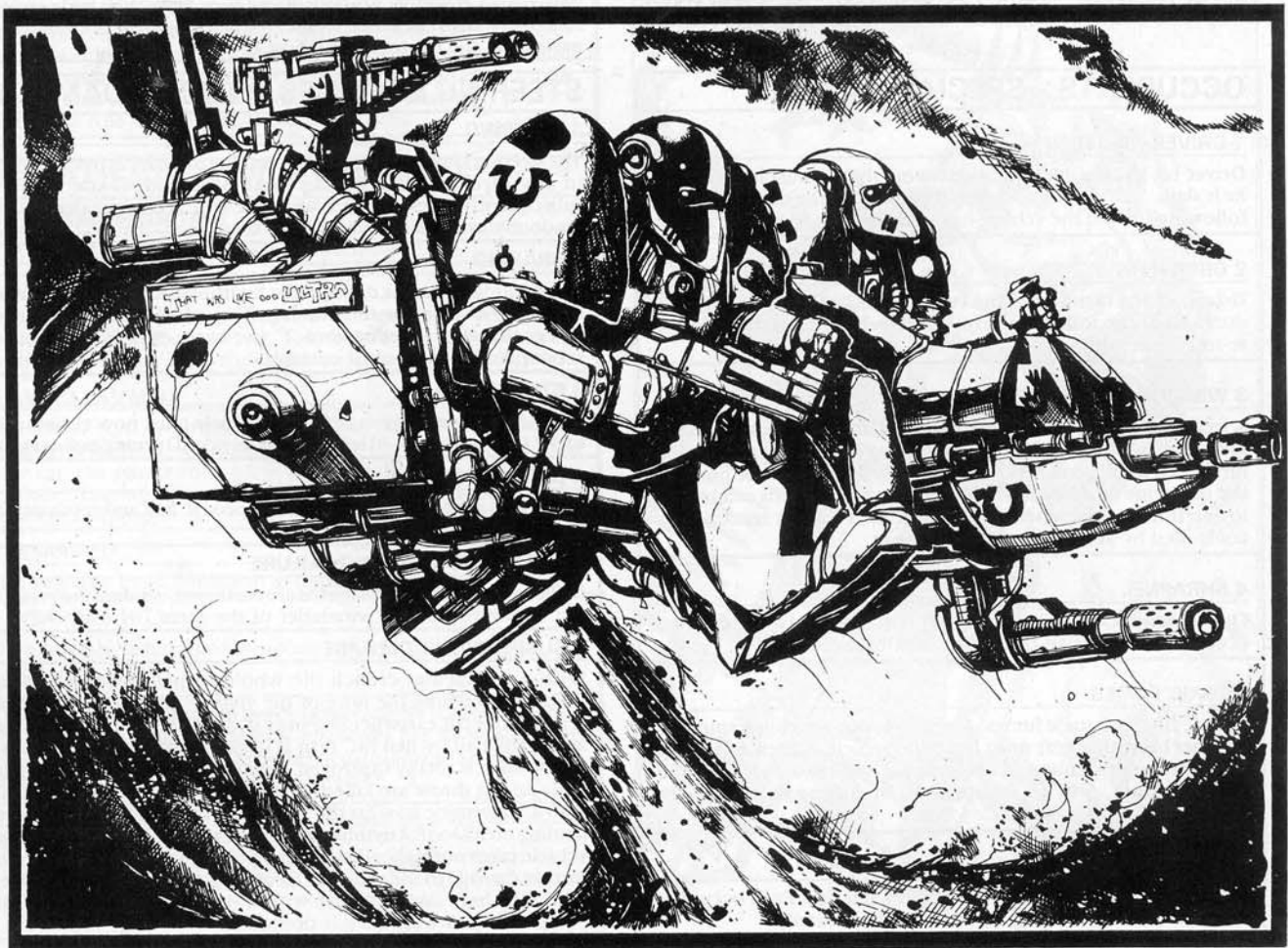



VEHICLE SPECIAL DAMAGE CHARTS

HIT LOCATION TABLE

Score (D6)	Affected System
1	OCCUPANTS
2	RUNNING GEAR
3	STEERING AND BRAKES
4	ARMAMENT
5	EQUIPMENT
6	MISCELLANEOUS

The new Special Damage Charts have been designed to replace the original damage chart on p39 of **WH40K**. The new charts are more detailed and make vehicles on the tabletop more durable. The main rule change is that vehicles reduced to zero damage points are no longer destroyed automatically.

Whenever a vehicle takes damage as a result of a hit, the player should roll a D6. If the vehicle received more than 1 point of damage from the hit, the player should add +1 to the dice score for each additional point of damage sustained. If the resulting score is 6 or more, then the shot has caused *special damage*. The player should roll another D6 and refer to the Hit Location Table. *For example, a vehicle suffers a hit causing 3 points of damage (2 of which are added to the D6 roll). The D6 roll is 4 (+2) = 6; therefore the vehicle suffers special damage. The vehicle player must now roll on the Hit Location Table.*

If a vehicle is reduced to zero points of damage, subsequent damage will automatically cause *special damage*. The player should roll a D6 and refer to the Hit Location Table.

When the system affected by the hit has been identified, the player should roll a D6 and consult the appropriate Special Damage Chart. Players should note down the result of *special damage*, together with any long term effects which result. A separate sheet of paper should be used for each vehicle.

OCCUPANTS - SPECIAL DAMAGE

1 DRIVER DISABLED

Driver hit and disabled. A basic saving throw must be rolled or he is slain. The vehicle goes out of control for the duration of the following turn. If the vehicle has an auto-drive re-roll the result.

2 DRIVER HIT

Driver hit and distracted. The vehicle goes out of control for the duration of the following turn. If the vehicle has an auto-drive re-roll the result.

3 WEAPON OPERATIVE

A weapon operative is caught by the blast and must make his basic saving throw or is killed. The weapon may not fire in its following turn, even if the gunner survives. If several weapons are present, the main one is affected. If there are several options randomise to determine which operative is hit. If the vehicle's armament is controlled by auto-fire re-roll this result.

4 SHRAPNEL

Occupants hit by flying shrapnel. D6 randomly determined occupants must make their basic save or are slain.

5 TOXIC FUMES

Vehicle fills with toxic fumes. Any troops not-wearing respirators or other breathing gear must leave the vehicle in their following turn. Any troops failing to evacuate the vehicle are slain on the D6 roll of a 4, 5 or 6. Troops with breathing apparatus are unaffected.

6 EXPLOSION

A massive explosion rakes the vehicle's interior. Each occupant must make a basic saving throw or is slain instantly.

RUNNING GEAR - SPECIAL DAMAGE

1 LINKAGE SHATTERS

Part of the linkage shatters and the vehicle twists to left or right before coming to a permanent halt. Roll a D6 to determine the track affected, 1-3 left; 4-6 right. Use a clock-face chart with 12 o'clock in the direction of travel to determine the direction the vehicle now faces. Roll a D6 if the right hand track is gone, a D6+6 if the left hand track is gone. If the vehicle is not tracked roll again on this chart.

2 WHEEL BLOWS OUT

A wheel disintegrates in the blast and the vehicle plunges down on its suspension, digging into the ground and grinding to a halt. The vehicle skids forward for D3" and stops. The vehicle ends its skid facing in a random direction - this can be established with a D12 and a clock-face chart. If the vehicle is not wheeled roll again on this chart.

3 GRAVITIC MOTOR MALFUNCTION

The blast fractures the main gravitic vacuum chamber sending the motor into an uncontrollable anti-gravitic reaction. The vehicle continues at the same speed and in the same direction, but rises by +10 height every turn until it is lost forever. If the vehicle is not a hover type roll again on this chart.

4 ENGINE DAMAGED

The engine is badly damaged as a result of the hit. With an embarrassing cough and distinctive plumes of white smoke, the vehicle totters feebly to a crawling pace. Reduce the vehicle's current speed by 4" per turn until it reaches 4". The vehicle may not accelerate further, and if it decelerates cannot accelerate again, not even to 4".

5 DRIVE TRAIN

The vehicle's drive train is shattered, sending it out of control next turn before coming to a sudden halt as part of the broken drive spears the body. If it was moving at greater than 10" before stopping, every occupant must make their basic save or suffer 1 wound. The vehicle will not move again.

6 TRACTION

The vehicle's main traction suddenly fails: wheels blow out; tracks fly off; gravitic reactors implode. The vehicle pivots across the ground, sliding against its broken side and spinning dangerously. The vehicle skids forward for D6" ending by facing a randomly determined direction. Any occupants must make their basic saving roll or are slain. Items of weaponry or equipment are rendered useless on the D6 roll of a 4,5 or 6.

STEERING & BRAKES - SPECIAL DAMAGE

1 STEERING

The steering system is damaged preventing the vehicle from moving in any direction other than straight ahead. If the vehicle subsequently goes out of control, it will accelerate/decelerate randomly as normal, but will not turn.

2 BRAKING

The braking system is damaged as hydroplastic lines shatter and control systems cease functioning. The vehicle's maximum rate of deceleration is reduced to 2" per turn, even if the vehicle subsequently goes out of control.

3 STEERING JAM

The steering mechanism jams. The vehicle must now either turn to the (1-3) right or (4-6) left using its standard turning radius ratio.

4 BRAKES JAM

The brakes seize, reducing maximum speed to half and acceleration to 2" per turn.

5 BRAKE AND STEERING FAILURE

Brakes and steering mechanisms are destroyed, sending the vehicle out of control for the remainder of the game.

6 SUSPENSION COLLAPSE

With a spectacular crunch the whole suspension mechanism collapses, pitching the nose of the vehicle into the ground and sending the tail cartwheeling over it. If the vehicle is travelling at less than 10" when hit, turn it upside down where it stands. The vehicle is totally destroyed. Occupants failing to make their basic saving throw are killed. If travelling at more than 10", roll 2D6 to determine how far the vehicle cartwheels forward before landing on its roof. Anything within the path of the cartwheeling vehicle takes normal collision damage, but does not stop it or do further damage to the vehicle. Occupants of the tumbling vehicle, who fail their saving throw with a -1 modifier, are slain. All equipment and weaponry is destroyed.



MISCELLANEOUS - SPECIAL DAMAGE

1 ACCELERATOR JAM

The vehicle's accelerator mechanism jams fast. The vehicle must accelerate by its maximum amount per turn. However, if there is a crewman available, he may attempt to rectify the problem at the beginning of each turn. Roll a D6, if the score is 5 or 6 the crew has freed the accelerator and the vehicle may then accelerate and decelerate as normal. Note that a vehicle may travel over its maximum speed, but is then subject to potential control loss.

2 ROLL

The shot throws the vehicle to one side, turning it over until it lands on its (1,2,3) side or (4,5,6) back. The vehicle should be moved D6" away from the source of the hit, or in a random direction if this is not appropriate. Any model in the rolling vehicle's path is collided with as normal. Occupants who fail to make their basic save are slain. Each weapon or item of equipment on the vehicle is rendered inoperative on the D6 roll of a 4, 5 or 6.

3 FUEL

The vehicle's fuel or power supply is ruptured and explodes. The vehicle immediately bursts into flames and goes out of control. The vehicle will explode at the end of any of its moves on the D6 score of 6. Any occupants must make their basic saving throw each turn or be killed.

4 TURRET

The turret is knocked out, destroying any associated weapon and equipment. If the vehicle has no turret, roll again on this chart.

5 DOORS JAM

All doors on the vehicle (1,2,3) jam shut or (4,5,6) fly open and cannot be closed. Jammed doors can be opened if there are troops inside. Roll a D6 at the end of each turn, on the score of a 6 the doors are prised open. If doors fly open, D6 randomly determined occupants will be thrown out of the vehicle and may take damage if the vehicle is travelling at greater than 10". If the vehicle is open topped and therefore has no doors (eg a land speeder), a sudden jolt throws D6 randomly determined models overboard.

6 AUTO-SYSTEMS DESTROYED

All auto-systems go completely haywire, operating in a random manner. These effects cannot be over-riden by the vehicle's occupants. Auto-drive causes the vehicle to move out of control. Auto-aim units fire weapons at randomly determined targets. Auto-fac systems only permit the use of an item of equipment on the D6 role of a 4, 5 or 6 made that turn. Doors may only be used on the D6 role of a 4, 5 or 6 made that turn.

ARMAMENT - SPECIAL DAMAGE

1 WEAPON DESTROYED

1 randomly determined weapon is destroyed.

2 AMMO BLOCKAGE

The ammo feed or power supply to one randomly determined weapon is blocked or severed. The vehicle may fire once more with that weapon, after which the weapon is rendered useless.

3 AMMO JAMMED

The ammo feed or power supply to one randomly determined weapon is jammed or fused. Every time the weapon fired from now on, the player rolls a D6. On the roll of a 6 the weapon explodes, causing D6 points of damage on the vehicle and *special damage* as appropriate.

4 DISARMED

The vehicle's main armament is destroyed.

5 WEAPONS HIT

D3 randomly determined weapons are destroyed.

6 AMMO HIT

The vehicle's central ammo bin or power supply is ruptured open and destroyed. The vehicle may no longer fire its weapons. In addition the vehicle takes D6 points of damage, and automatically takes D3 further *special damage* effects.

EQUIPMENT - SPECIAL DAMAGE

1 TARGETER

1 randomly determined targeter is destroyed. If the vehicle has no functioning targeter, roll the result on the *armament* chart.

2 POWER FIELD SYNCHRONISER

The vehicle's PFS is destroyed. If the vehicle has no PFS roll again on this chart.

3 POWER FIELD

The vehicle's PF generator is destroyed. If the vehicle has no PF, roll the result on the *miscellaneous* chart.

4 CENTRAL CONTROL SYSTEM DAMAGED

The shot damages the vehicle's control systems. This can have many effects, sending random surges of power rushing through the vehicle's circuits, melting delicate components, causing explosions, random burn-outs and control loss.

To reflect this random and often cataclysmic level of escalating damage, throw each turn. On a 4, 5 or 6 the vehicle takes another random *special damage* result. The only way to halt this effect is to abandon the vehicle altogether.

5 AUTO-SYSTEMS

Damage to the auto-system control unit destroys all on-board auto-systems instantly including auto-drive, auto-aim and auto-fac. If under auto-drive when hit, the vehicle goes out of control for the duration of the following turn (assuming a crewman can take over) or permanently (if no crew are available to take over).

6 WIPE OUT

Overwhelming damage to the central control system results in every item listed as part of the vehicle's equipment being rendered instantly unusable. If the vehicle is under auto-drive when hit, see entry 5 above.

Wisdom is the beginning of fear



Praise the sun that brings the dawn
Of our final doom.

EXTRA EQUIPMENT

The new power field and field synchroniser rules described in *White Dwarf* 100 (see Chapter Approved - Dreadnoughts) also apply to vehicles.

Power Fields. Points cost 10 each per 1" radius. Power Fields of 1" radius are assumed to cover the entirety of any small or medium sized vehicle. A large vehicle requires a 2" radius field. Power Fields of larger radii may be fitted, costing 10pts for each extra 1" radius. A vehicle may carry several different shields, although only one may be active at any time. A Power Field may be turned *on* or *off* at the *start* of the player's turn. It may not be turned on or off once the vehicle has been rendered immobile as a result of damage. Once a Power Field is activated a vehicle may not fire weapons through it.

The presence of a Power Field around a vehicle does not affect its movement, nor does it make any difference to the result of a collision with another vehicle. The field is designed in such a way that it flows around obstacles in its path, otherwise the vehicle would be in permanent collision with irregularities in the terrain.

Power Field Synchroniser. Points cost 10 points each. These are valuable devices which allow a Power Field to flick off during the brief moment it takes to fire a weapon. If a vehicle has a Power Field Synchroniser it may fire weapons during its own shooting phase, even though the Power Field is on. However, to represent the chance of an enemy shot sneaking through as the field flicks off, any shot against the vehicle in the enemy's following turn will penetrate the Power Field on the D6 score of a 5 or 6. This does not destroy the field: the shot simply by-passes it during its split second of inactivity.

SHIELD PENETRATION

As described above, a shield is penetrated on the D6 score of a 5 or 6 if it was fired through in the preceding turn. Alternatively you may divide the turn into six 'phases' 1-6. The player wishing to fire a weapon secretly writes down the phase in which each weapon fires. A *following fire* weapon may fire over several phases - one shot corresponding to one phase - but may not fire through more than 6 phases. The shield is down for *all* the phases in which the weapon fires.

In the enemy's following turn, when weapons are fired against the shielded vehicle, the player must try to guess the phase written down by the other player. Most weapons entitle the player to one guess. If the guess is correct, and the shot hits, the shield is penetrated. If it's incorrect the shield is hit as normal. Players whose weapons have an area effect are entitled to two guesses to represent the spread of separate impacts at slightly different times. Players with following fire weapons are entitled to one guess the first time they hit, and each succeeding hit adds 1 to the original number guessed. So, if your first guess is 3 the second hit will be 4, a third 5, and so on.

If a shielded vehicle is being fired at by several different attackers, resolve each guess individually but allow the vehicle player to change the nominated phase(s) in between each of his opponent's guesses. This is a bit unrealistic, because the weapon can only really fire in one phase. However, it prevents the attacker nominating successive phases to his unfair advantage - impossible in the heat of battle.

"I cry out for troops and you give me rhetoric - I plead for ammunition and you give me speeches - I ask you again, Commander, what can you pledge me?"

"A heroic death, Captain."

Reported holocom conversation between Commander Gulim Tarrel and Captain Roima of the besieged Alharmo garrison shortly before the final Ork assault.

CONTROL LOSS

A vehicle may either go out of control for *one turn* or *permanently*. If a vehicle goes out of control permanently it is not possible to regain control - a vital mechanical component has been affected. A vehicle which has gone permanently put of control will accelerate/decelerate and turn randomly as described in **WH40K** (pp39-40) until it either leaves the table or comes to a halt. The vehicle will then remain stationary.

A vehicle which goes out of control for one turn automatically regains control in the following turn and may move under the full control of the player. The only exception is if the vehicle goes out of control *again* - either because it exceeds its maximum speed and fails the required dice test, collides with a solid object, or receives another *out of control* result on the Special Damage Charts.

OPEN TOPPED VEHICLES AND EXPOSED CREW

Note that the rules for firing at exposed individuals remain as given in **WH40K** p39. Any exposed crew member (including crew sticking their heads out of hatches, firing uncovered weapons, or riding bikes) may be specifically targeted by a firer within the short range of his weapon. If a player wishes to fire at an exposed crewman or bike rider, he must declare his intention before he shoots.

Shots against open vehicles, including bikes and land-speeders, always stand a chance of hitting exposed crew even if the player doesn't intend to fire directly at them. Hits against open vehicles and bikes must be randomised between crew (1,2,3) and vehicle (4,5,6). Crewmen sticking their heads out of hatches in enclosed vehicles are never hit randomly - the only way they can be hit is if they are specifically targeted as described above.

RICK PRIESTLEY



GAMES™
WORKSHOP



GAMES WORKSHOP STORES
Putting gaming on the map.

IN THE UK...

- ★ **SOUTHAMPTON:** 23 East Street, Tel: 0703 331962 (Manager: Adrian Weston)
- ★ **LONDON:** Plaza Centre, Oxford Street, NW1. Tel: 01 436 0839 (Manager: Phil Brough)
- ★ **LONDON:** 1 Dalling Road, Hammersmith W6. Tel: 01 741 3445 (Manager: Pete Armstrong)
- ★ **BIRMINGHAM:** 37, West Terrace, The Pallasades. Tel: 021 632 4804 (Manager: Dave Howard)
- ★ **LEEDS:** 12/16 Central Road. Tel: 0532 420834 (Manager: Val Eyles-Owen) Closed: Tuesdays.
- ★ **MANCHESTER:** Unit 162, Marsden Way, Arndale Centre. Tel: 061 832 6863 (Manager: Karl Hulme)
- ★ **NEWCASTLE:** 63 Clayton St. Tel: 0912 322418. Closed: Wednesdays (Manager: Ian Henzell)
- ★ **NOTTINGHAM:** 41A Broadwalk, Broadmarsh Centre. Tel: 0602 585744 (Manager: Colin Morris)
- ★ **SHEFFIELD:** 95 The Moor. Tel: 0742 750114. Closed: Wednesdays (Manager: Paul Castleton)
- ★ **YORK:** 26 Goodramgate. Tel: 0904 653575 (Manager: Evan Moss) Closed: Wednesdays
- ★ **DERBY:** 42 Sadler Gate. Tel: 0332 376657 (Manager: Colin Morris) Closed: Wednesdays
- ★ **LIVERPOOL:** 23 Bold Street. Tel: 051 708 6087. Closed: Wednesdays (Manager: Karl Hulme)
- ★ **BECKENHAM:** 292-294 High Street, Kent (Manager: Colin Haisell)
- ★ **HARROW:** 296 Station Road

AND IN THE USA:

- ★ **BALTIMORE/WASHINGTON AREA:** Unit F3, Laurel Centre Mall, Laurel, Maryland 20707. (Manager: Tim Olsen)

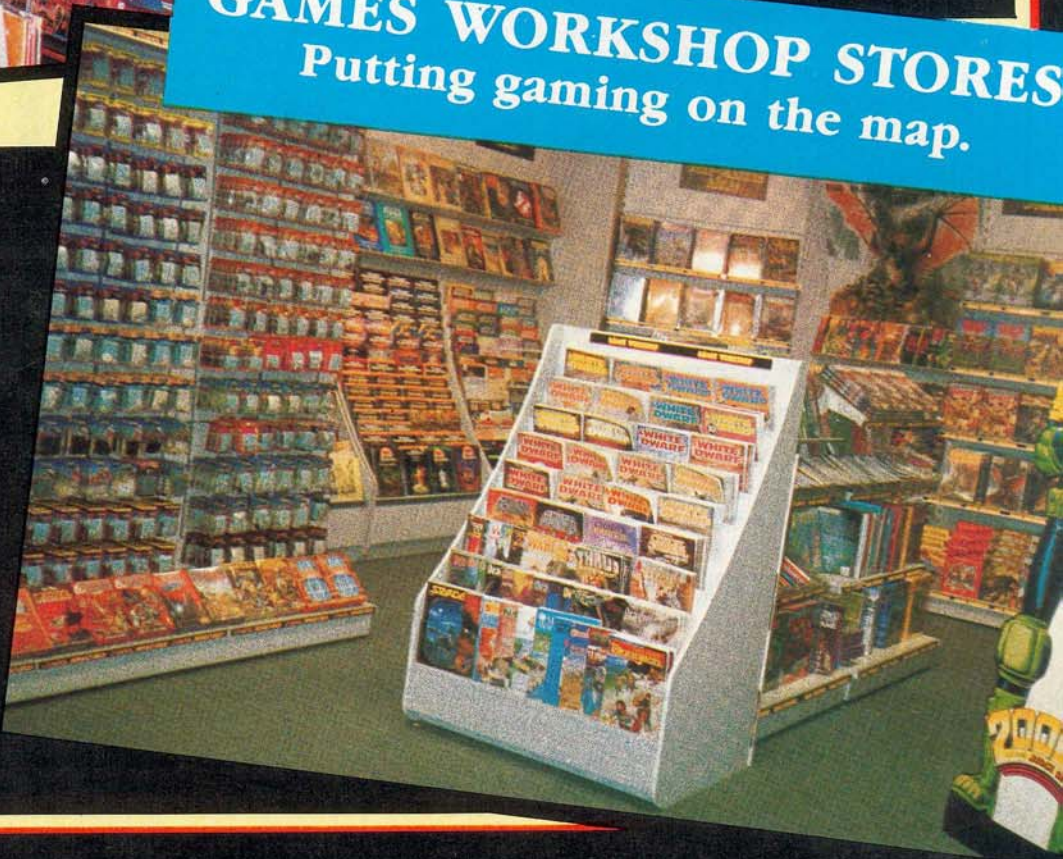

Proudly Announcing the Grand Opening of
Harrow's Newest Games Shop

GAMES WORKSHOP™ HARROW

● **SPECIAL OPENING OFFERS AT
GAMES WORKSHOP
HARROW!**

Look out for super bargains and special offers all day!

● **FANCY DRESS COMPETITION! £50 PRIZE!**
There will be a prize of a voucher for £50 worth of GAMES WORKSHOP products for the fantasy outfit we like best. Come as an Orc or a Wizard or anything you like - but don't bring any weapons, please.

● **BARGAIN GAMES!**

All 3 Warhammer Rulebooks (Warhammer Fantasy Battle, Warhammer Fantasy Roleplay and Warhammer 40K) At just £25.00 the set! (LIMITED STOCKS ONLY)

● **100 GAMES AT £1.00 EACH!**

Special bargains on the day include the first 100 games at just £1.00 each! Including:
10 x DUNGEONQUEST, 10 x WARHAMMER 40,000,
10 x WARHAMMER FANTASY BATTLE (THIRD EDITION), 10 x WARHAMMER FANTASY ROLEPLAY, 10 x FURY OF DRACULA,
10 x TALISMAN, 10 x CALL OF CTHULHU,
10 x BLOCK MANIA, 10 x JUDGE DREDD ROLEPLAY, 10 x BLOODBOWL!
(Max. 1 bargain game per customer while stocks last)

● **PLUS:**

The first 10 people in the queue to receive a special Limited Edition T-shirt (bound to be a collectors item!) and there'll be special 'I Was There' T-shirts as well!

● **CELEBRITIES!**

Look out for the GAMES WORKSHOP celebrities as well as the fantastic MYTHLORE creatures and monsters!

Please note that all special offers apply only to Games Workshop Harrow on the Grand Opening Day, 16th July 1988!

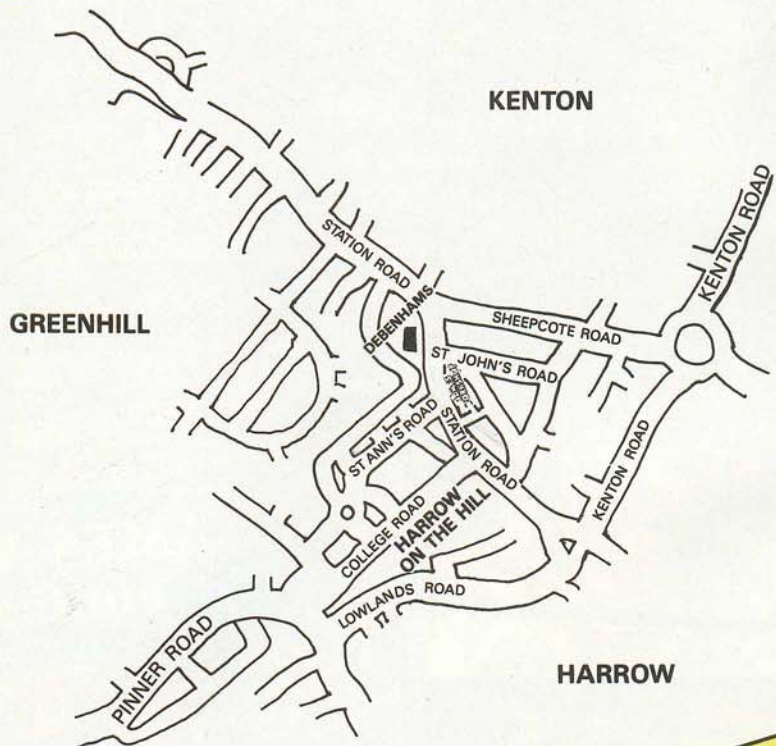

at
296 Station Road, Harrow
Tel: 01 863 0412

ON SATURDAY JULY 16th 1988!
Doors Open Early!

Normal opening times 9.30am-5.30pm Monday-Saturday
Nearest underground station: Metropolitan Line — Harrow on the Hill,
also British Rail and Bus Station at same junction



LETTERS PAGE,
WHITE DWARF,
ENFIELD CHAMBERS
14-16 LOW PAVEMENT,
NOTTINGHAM,
NG1 7DL

**WHITE
DWARF**

Hello, you're just time for a cosy discussion about Undead, atmosphere, celibacy...

Lori Dunn, Canada Trivial nit-picking though it may be, I wonder whether Skeletons should be allowed standard bearers in *WFB*. According to the rules, Skeletons are creatures that need to be magically controlled by a wizard, liche or undead hero. Skeletons do not rout, so they aren't plagued by a flesh-and-blood outlook. ('Look! George is dead! And Fred! And Bill! Let's get the %*%@ out of here!') They fight to the last pile of broken bones because Skeletons lack a will of their own.

In battle, standard bearers are used for practical aspects of rallying troops and signalling movement. Here the use of standards is logical. As an extension of this, we arrive at the standard's ability to inspire troops to greater efforts by acting as a focus for the unit's pride. So, in hand-to-hand combat, a unit with a standard receives a +1W bonus since they will push ahead even if sorely pressed and will follow their flag eagerly.

This is why I believe Skeletons (the only Undead that I looked into) should not receive the bonus for the standard. The practical rallying use is fine, but to receive the bonus, the unit must feel the effects of morale - a trait shared by living creatures but not the magically animated Skeletons who have no life, or will, of their own.

Rick Priestley replies: In game terms, perhaps standard bearers seem illogical at first, but they add to the mystique and appearance of the unit carrying them. All units look better with a nicely painted standard so why deprive a collector of Undead the chance to show off his painting skills?

We might cite some residual sense of purpose, loyalty or pride as part of the magical power that animates the Undead but whether the presence of a standard should contribute to the fighting efficiency of the Skeletons is another thing - and I can certainly see grounds for your argument. Worthy of an amendment perhaps? Perhaps! But I'll bet there are a few players out there with Undead armies who'd like to take up the case against.

Kevin B Spiller, Chelmsford After reading the excellent article on *Warhammer* strategy (WD 101) I felt there was a need to put another side to the story. Points values as they stand are a controversial, and for a competition game, probably necessary, anomaly. However, it would be better if they were only used as a guide to troop capability. Using points values too rigidly means that the atmosphere of the game gets dictated by gamers moving their 5 point Orc heavy infantry armed with shields to score hopefully high dice rolls against a level 2 wizard... I feel that a better game comes from thinking of your figures as real Elves/Dwarfs/Goblins and leading your well armed, highly confident retinue against the threat of the enemy on the flank. Troops should not be identified by points values but by descriptions based on the range between observer and target. Maybe the enemy in the distance only appear as humanoids armed with spears - or maybe their banner is recognised and described.

Tactics should be dictated by the military capabilities of the unit and the way the troops think, not the rulebooks. When playing with an Orc army, think Orcish, if playing a Norscan army, think Viking. Tactics that work best with your army would work with a real life equivalent (problems with the Undead here), regardless of points values. I was using shield walls and wedge formations long before *WFB III*. I have a number of armies (over three hundred figures in each), and don't know the points value of any of them. Generalship and leadership qualities are best displayed when using unequal forces.

Invent or adapt a history for your army. This can be entirely fictitious or based on some medieval, gothic or *Warhammer* nation. The histories themselves can lead to some interesting scenarios based on generations old feuds, or whatever. Possibly the best and most far sighted guideline in the rules is the "Rules versus ideas" paragraph on p81, don't be afraid to experiment. Happy gaming.

And the same to you.

James Whitaker, W Yorks Please please can you give some advice to my friend? We have been playing *WFB* since it came out. However, of the countless Dwarf-Elf engagements, my friend (the Dwarf) has only won two. He has approximately one hundred Dwarfs, 2 bolt throwers, the gob-lobber, gyrocopters and the flame cannon to take on exactly 52 Elves and a chariot.

Does he lose because he's a bad commander or has he pitched for the wrong race? It's getting so that before we even start a battle, he says he's going to lose and that Dwarfs are rubbish. Give him some help before I obliterate all the Dwarfs in the Old World. I'm off to do some stuntie stomping.

Sounds like he's going badly wrong somewhere. Dwarfs are certainly not the 'wrong' race. Try swapping forces and varying the scenery in each battle.

And the same to you.

Teela Webart-Murmann, Newport THANK YOU for releasing *Power Behind the Throne*. We have been playing since Christmas without a scenario - no mean feat.

Every week, without fail, seven men in strange gear turn up on my doorstep. Depending on his shift, my husband either leaves within the hour or arrives very late. The neighbours have tried to discover what goes on, my brother-in-law has accused me of having a party when he knew that my husband was on nights, and why? *WFRP*, that's why!

From the first session of the *Enemy Within* we have played every Wednesday. A classic phrase has been coined. "Who rattled your cage?" This was said to the protagonist and put poor Rowlocks out cold for an hour. He was concussed for days. He lost all his money in the same fracas (Kirsten) so he couldn't go to the temple of Shallya.

They survived Bogenhafen - just. They acquired a boat, sailed up and down the river Reik getting lost, drunk, wounded, scared, seduced, ripped off and confused. They killed Goblins, mutant butterflies, Ghouls, Skeletons, a poor innocent squirrel, smelly guards...

Now they are on the road from Delberz to Middenheim, having left the boat in the boat yard to be over-hauled and painted pink (Kirsten). The goat, rabbits and ducks have been left in the care of Heironymous Blitzen. Just out of curiosity, are there any special rites in the cult of Sigmar with regard to marriage? Pickaxe got drunk and made promises he can't remember to a girl who won't let go. While I'm on the topic, are priests of Sigmar celibate? Ever since Pickaxe found the sword Barrakul he has been convinced that he's on a MISSION FROM THE GODS! and he now prays every day, morning and evening, before he uses the sword.

Kirsten has hit out for place unknown - in the middle of the night with only Melody, her cat, for company, she went with a messenger. The others think she has gone to Kemperbad. Wanda has warped off to Altdorf to do some research.

I have had to start a card index for all the shops - bakeries, tailors, candlestick makers - in every town because the blighters keep ordering things and then going back for them. So if you need a few merchants - good, bad and indifferent, just ask, for example, for trail rations and high class grocery and provision merchants. You can't do better than Heinrich Harrod, Food Emporium, Alte Marktplatz, Kemperbad. Expensive, high quality, the cost of everything multiplied by four.

Mutant butterflies? Put your analyst on danger money. No, there are no special rites for marriage other than a mutual exchange of promises, in a temple, before a congregation, to a priest of the cult. Clerics of Sigmar are not bound to celibacy. But priests of Ulric are...

As for your campaign, you're doing a wonderful job.

Letters cosily edited by Sean Masterson

DARK FUTURE™

When America degenerates into continental desert, dotted with affluent, mega-tech Police Zone fortress towns (PeeZees) and their desolated neighbourhoods (the shanties and slums of NoGo), the Interstate highways become the front-line of a ceaseless struggle against crooks, desperados, anarchists, bandits and fanatical followers of religious cults. The freeway killing grounds are patrolled by a new generation of law enforcers - Sanctioned Ops.

Choose your vehicles and weapon payloads. Play fast, do-or-die chases, or head-on intercept missions. The 'rolling' track system adds an element of unpredictability as you place new track sections (to generate corners, curves, long straights and random hazards) ahead of the speeding combatants.

No other game gives you the pace or feel of combat driving. Richard Halliwell's ready-to-play rules are tested to destruction, and form an introduction to a new games system and a gateway to a new world.

The game comprises plastic car and bike models (with a full armoury of slot-in weapon systems), over five metres of track, a detailed rulebook with quick-start options, record sheets, dice and the full background of the Dark Future world itself, evoked by the artwork of Critchlow and Knifton, and described by Marc Gascoigne.

DARK FUTURE - DEATH IN THE FAST LANE

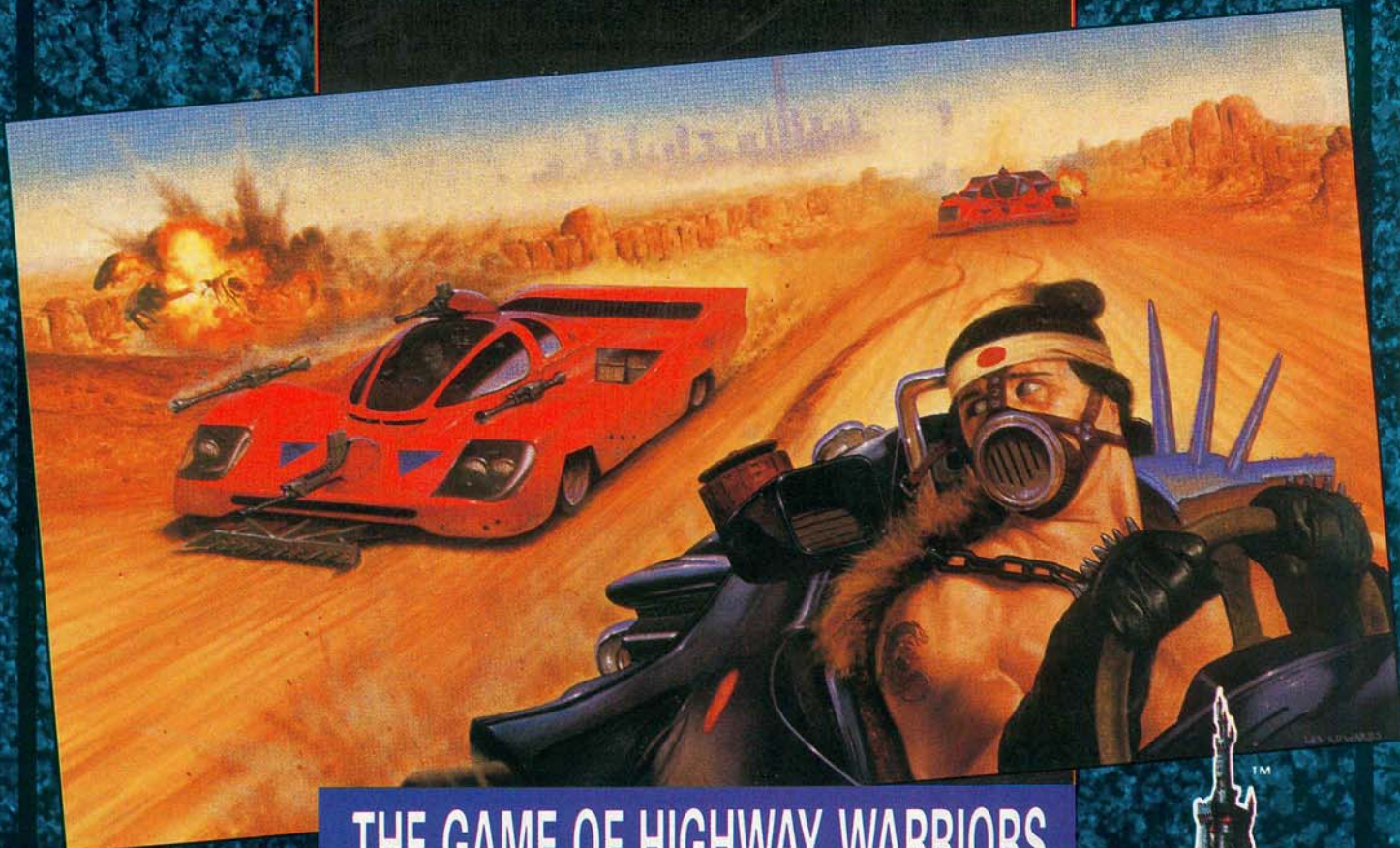

THE GAME OF HIGHWAY WARRIORS

AVAILABLE THIS SUMMER
PRICE £19.99

GAMES™
WORKSHOP



CITADEL™
MINIATURES

HIGHWAY HOLOCAUST

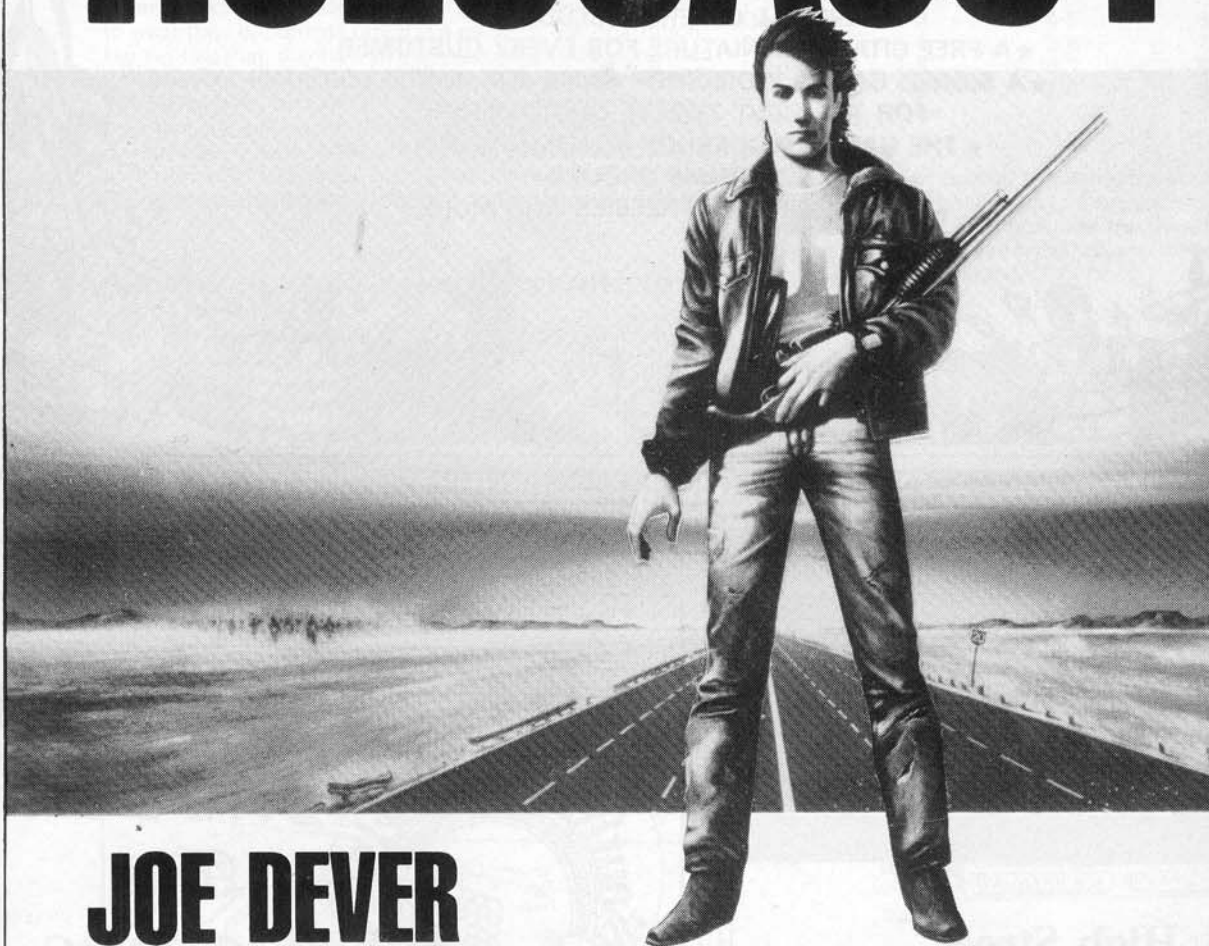

JOE DEVER

From the author of the best-selling series **LONE WOLF**

HIGHWAY HOLOCAUST is the first in a spectacular new series of solo adventures written by Joe Dever, author of the award-winning **LONE WOLF** adventure gamebooks. Each exciting episode can be played individually, or you can combine them with others in the series to create a solo role-playing epic.

AMERICA 2020AD. Eight years ago the terrorist agents of H.A.V.O.C. triggered a nuclear nightmare that devastated the northern hemisphere,

its radioactive aftermath claiming all but a few lucky survivors. Patiently, in scattered colonies deep underground, these survivors have been waiting for the earth to heal itself, waiting for the day when they could walk once more upon the surface of their shattered world. That day has come... but the real battle for survival has only just begun!

You are Cal Phoenix, the freeway warrior, champion and protector of Dallas Colony One. A murderous gang of H.A.V.O.C. clansmen, led by the

psychotic Mad Dog Michigan, are bent on destroying your fragile colony as it crosses the wastelands of Texas on the first stage of a life-or-death exodus to the California coast. These bike-riding clansmen are a formidable enemy: armed, cunning, and extremely dangerous, capable of launching a lightning raid at any time, day or night. You will need all your wits about you if you are to defend your people and reach your destination intact!

ONLY £2.50
FROM ALL GOOD BOOKSHOPS
AND GAME STORES

FREEMWAY WARRIOR 1 BEAVER



THE THIRD **GAMES WORKSHOP** SPECIALIST STOCKIST IS...

GAMES & PUZZLES

MEGA RE-OPENING DAY ON 9TH JULY 1988
IN HUGE NEW PREMISES AT

GAMES & PUZZLES
SIR ISAACS WALK
COLCHESTER
ESSEX

TEL: 0206 574781

SPECIAL OFFERS INCLUDE:

- ★ A FREE CITADEL MINIATURE FOR EVERY CUSTOMER
- ★ A SIGNED GAMES WORKSHOP GAME FOR JUST £1.00 FOR THE FIRST TWELVE CUSTOMERS
- ★ THE GAMES WORKSHOP ROADSHOW TEAM
- ★ COSTUME GROUPS
- ★ SPECIAL OFFERS, FREEBIES AND MORE

JUST 50 YARDS
FROM OLD SHOP

NEW SELF SERVICE
FIGURE BAR



Encounter GAMES

7, High Street
Arcade,
Cardiff

Tel: 0222 21159



Southsea
Models
And
Games

69 Albert Road, Southsea, Portsmouth

GAMES WORKSHOP SPECIALIST STOCKISTS CARRY A FULL RANGE OF BOTH GAMES WORKSHOP AND CITADEL MINIATURES PRODUCTS, PLUS ALL NEW RELEASES AS SOON AS THEY ARE AVAILABLE



THE LONG AND THE SHORT OF IT

Jervis Johnson tells you everything you could possibly want to know about Dwarf and Elf teams.

DWARF TEAMS

Dwarfs were one of the first races to form teams and leagues to play Blood Bowl. Many Dwarf teams in the current league can trace their history back to the early years of the game.

Dwarfs tend to use a conservative running game, attempting to wear their opponents down in a grinding war of attrition. Having said that, there are so many Dwarf teams around that it's easy to find one to suit every taste: the Dwarf Warhammerers, for example, have a reputation for breaking the rules in the most obvious and flamboyant fashion, while Durum's Destroyers of Albion's Northern Premier League have built up a solid reputation for a good passing game (thanks mainly to the inspired leadership of Bran 'Long Bomb' Ironson).

DWARF PLAYER CHARACTERISTICS

	MA	SP	ST	AG	TS	CL	AV
Lineman	3	+2	4	2	-1	0	10
Blocker	3	+1	5	2	-1	-1	10
Blitzer	3	+3	4	3	-1	+1	10
Thrower	3	+2	3	3	+1	0	9

A typical Dwarf team will have 6 Blockers, 4 Blitzers, and 6 Linemen, though there are many local variations on this basic format. Note that a typical Dwarf team does *not* have a Thrower, though this is not to say that such players are unheard of - they are just rather rare. If you want to include Throwers, reduce the number of Blitzers by 2 and add 2 Throwers to the team.

Dwarfs may never be Catchers. If you are using the rules for Kickers (WD 102), they have the same characteristics as Throwers. Up to 2 Dwarf Kickers may be included in a team, replacing Linemen on a 1 for 1 basis.

SPECIAL RULES

Throwing

Dwarf teams are not renowned for their passing game. Their height makes it easy for opponents to intercept their passes, while at the same time making it more difficult for them to pick off a badly thrown ball. To reflect this, use the following special rules when fielding a Dwarf team.

When a Dwarf throws the ball, use the *Dwarf Throwing Table* instead of the one printed in **Blood Bowl**.

Dwarf Throwing Table

Range	Interception	Missed	Caught
Quick Pass	2-3	4-5	6-12
Short Pass	2-4	5-6	7-12
Long Pass	2-5	6-7	8-12
Long Bomb!	2-6	7-8	9-12

Interceptions

Whenever a Dwarf is used to *Intercept* a throw, roll a dice. On a 3-6 the Dwarf manages to *Intercept* the ball as in the normal rules. On a 1 or 2, however, the Dwarf was not able to jump high enough to catch the ball, and the result is treated as a *Missed* throw instead.

Injuries

Dwarfs are naturally very tough, and recover from being KO'd faster than most other races. To represent this in the game, Dwarfs count KO'd results from the Injury Table as Stunned results instead.

Dislikes & Animosity

Dwarfs dislike Elves, who they find arrogant and irritating, and with whom they have little in common. If Dwarfs and Elves are in the same team, a Dwarf will only Hand-Off or Throw the ball to an Elf if 4 or more is rolled on D6. If the roll is failed the Dwarf may only pass the ball to another Dwarf or Human player, otherwise the Dwarf in possession must hold on to it.

Dwarfs suffer *animosity* towards all Goblinoids (Orcs, Hobboblins, Goblins and Snotlings) and will not play in the same team as a Goblinoid creature.





ELF TEAMS

Elves used to hold the opinion that there was no more to Blood Bowl than two groups of uncivilised yobs beating each other senseless in a display of mindless violence. After a while, however, they came to realise that while reciting poetry has its place, seeing your team wipe out the opposition and win a hard fought Blood Bowl game is even better!

Elf teams, of which there are now quite a few in the NAF, are renowned for their passing game. All the most famous Elf players are either Throwers or Catchers, though there have been several quite effective Elf Blitzers in recent times.

ELF PLAYER CHARACTERISTICS

	MA	SP	ST	AG	TS	CL	AV
Lineman	4	+3	3	3	+1	+1	8
Blitzer	4	+3	4	3	+1	+1	9
Catcher	4	+4	2	4	0	+2	8
Thrower	4	+3	3	3	+2	0	8

Most Elf teams have 2 Throwers, 6 Catchers, and 8 Linemen, though a few include 2 Blitzers in their line-up instead of 2 of the Catchers. Elves may never be Blockers. If you are using the rules for Kickers (WD 102), they have the same characteristics as a Lineman. Up to 2 Elf Kickers may be included in a team, replacing Linemen on a 1 for 1 basis.

SPECIAL RULES

Interceptions

In addition to their ability to pass the ball, Elves are highly effective at *Intercepting* the ball when the other team throws it. To reflect this, Elf players get the *Intercept Skill* (Level 1) for free. This skill is the same as the *Intercept Skill* found on some of the Freebooter cards included in WD 101 and 102:

Intercept: This player can convert *Missed* throws by the opposing team into *Interceptions*. The player can only use this ability if they are eligible to *Intercept* the throw. To find out if a *Missed* throw is *Intercepted*, roll a dice and add the player's skill level to the score. If the total is 7 or more, treat the result as an *Interception* instead of *Missed*. Only one player may use their *Intercept Skill* per *Missed* throw.

Injuries

Most Elf players are not really cut out for the smashing effect of a block or hard tackle - it messes up their hair, more often than not gets their outfit dirty, and, oh, those unsightly bruises! The Elves' distaste for direct physical contact is partially reflected in their low AV, but in addition, Elf players take longer to recover from Stunned and KO'd results than players belonging to other races.

KO'd Elf players are moved to the Stunned box after a Touchdown is scored. They are never moved straight to the Reserves box.

After a Touchdown, roll a dice for each Elf player in the Stunned box of the Dug-Out. On a 3-6 they are moved to the Reserves box as normal, but if a 1 or 2 is rolled, they have to stay where they are.

Elf Blitzers

In recent times Elf teams have started to include some surprisingly effective Blitzers in their line-up, who actually seem to *like* the idea of a good fist-fight. Many Elves blame this worrying development on the desensitizing effect of Cabalvision on the minds of the young, though the various broadcasting companies deny that there is any solid evidence for this claim.

Whatever the reason, this new breed of Elf player seems to spend far less time in the Dug-Out after an injury than do other Elf players, and so can ignore the special Elf Injury rules above.







Dislikes and Animosity





Elves are a proud and aloof race, having a well deserved reputation for not getting on very well with other races. Elves suffer *animosity* towards all Goblinoids and Large Monsters (Ogres, Trolls and Minotaurs), and will not serve on the same team as any of these creatures. They dislike all other races, and will only Hand-Off or Throw the ball to a non-Elf player if a 4-6 is first rolled on a dice. If the roll is failed they must pass the ball to another Elf or hang onto it themselves.

BLOOD BOWL™

TEAM CARDS

Cut out and use the two team cards presented here instead of the ones in the **Blood Bowl** game. If you use the figures in the game to represent these races, you'll need to write down what type of player each piece represents, as you might not have enough special player bases. Of course a much better idea is to use the appropriate figures from Citadel's range of metal Blood Bowl miniatures.

BLOCKER	BLITZER	LINEMAN	THROWER
			
MA SP ST AG TS CL AV	MA SP ST AG TS CL AV	MA SP ST AG TS CL AV	MA SP ST AG TS CL AV
3 +1 5 2 -1 -1 10	3 +3 4 3 -1 +1 10	3 +2 4 2 -1 0 10	3 +2 3 3 +1 0 9

BLITZER	LINEMAN	THROWER	CATCHER
			
MA SP ST AG TS CL AV	MA SP ST AG TS CL AV	MA SP ST AG TS CL AV	MA SP ST AG TS CL AV
4 +3 4 3 +1 +1 9	4 +3 3 3 +1 +1 8	4 +3 3 3 +2 0 8	4 +4 2 4 0 +2 8



DWARF BLOCKER
DURUMS DESTROYERS

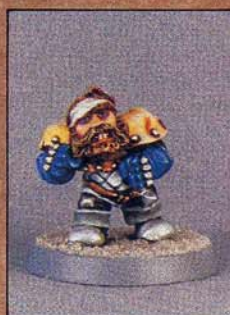

DWARF BLITZER
DWARF GIANTS



ELF BLITZER
GALADRIETH GLADIATORS



ELF LINEMAN
CODILLION CLARIONS



ELF CATCHER
ELFHEIM EAGLES

ON THE BOIL

Graeme Davis on Characters and Careers in WFRP

Martin Brown, Dunblane: The Noble's trappings include *bangers-on* - what are they?

The Noble is a somewhat exceptional basic career because of the advantages it confers on a character. Bangers-on are one such advantage. For a PC Noble, these will be Servants and Bodyguards for the most part, although all kinds of people will attach themselves to a Noble in the hope of profiting by the association. Note that Loyalty tests will be in order if the Noble indulges in excessive and/or dangerous behaviour (eg "I say, Jeeves, you just hold this dragon off for a few minutes while I make sure everyone gets away safely"). For an NPC Noble, the nature of the bangers-on will depend on the circumstances; at home there will be Servants and Bodyguards, while on a night on the town the Noble is more likely to be accompanied by like-minded pleasure-seekers such as Bawds. If an NPC Noble comes from a particularly exalted family, one or more of the bangers-on may even be lesser Nobles themselves.

Mark Dexter, Glossop: Please could you tell me if there are more character races than Human, Elf, Dwarf and Halfling. My friend says you can be any type of beast in the Bestiary, and wants to be a Warrior of Chaos - please tell me if this is possible.

As the rules stand at present, player characters may only be Humans, Elves, Dwarfs, Halflings or Gnomes (see WD86). You definitely can't be anything from the Bestiary. Having said that, Realm of Chaos will have rules for player character Chaos Warriors and Chaos Sorcerers, but your friend will have a long way to go before his Chaos Warrior character will be as powerful as the one in the Bestiary. I think he's just trying to get a super-powerful character. Of course, no-one would ever go adventuring with a Chaos Warrior, and they would be hated and feared wherever they went, with Witch-Hunters popping up everywhere just itching to burn them at the stake.

Gavin Orpin, Isle of Sheppey: I would like to know if Halflings, Dwarfs or Elves can become Templars. If so, can they serve Human religions, or must they follow one of their own religions?

*Good question. On the whole, nonhumans follow their own gods - many Human gods have nonhuman equivalents (see **The Enemy Within**, p21) - but there is no reason why a nonhuman who has spent a long time in Human society shouldn't take to worshipping Human gods. However, it will be difficult for a nonhuman to become a Cleric or Templar in a Human cult. If one of your players wants to do this, the character will have to spend quite some time proving him/herself and overcoming the natural prejudices of the cult's Human leaders.*

James Anderson, Edinburgh: It says in the rulebook that followers of the Old Faith, namely Druids, must be Neutral. Now, as we all know, Druids are dedicated to the protection of animals, forests, etc. Under *Good* in the section on Alignment it states that *Good* characters are 'for natural order, peace and beauty'. So why the restriction on alignment? Also, this would allow Elves to become Druidic Priests - after all, they are brought up in woodlands, so what is more natural than an Elven Druid?

The reason we decided that Druids have to be of Neutral alignment is because they believe in the rule of nature, and nature is a system in which Human (and Elven) moral terms such as good and evil are irrelevant - it's neither good nor evil, it is simply there. We decided to keep Human and Elven religions separate, and since the Old Faith is tied very closely to the origins of Human society we decided that it is not a religion which would be open to nonhumans.

Of course, elven (or other non human) nature cults might have a similar outlook to Druids, and an Elf could always follow one of these.

Philip Bartley: One of my PCs has the *Ambidextrous* skill. Can he attack and parry in the same round if he only has one Attack?

No. But if he's wounded in one arm he can use a weapon in the other with no penalties.

Roger Eng, Vanersborg, Sweden: If a character starts with the maximum Int 40 and WP 40, and makes it to Wizard level 4, can he never rise above Int 70 and WP 70?

No - he can never increase his Int and WP above 70 unless he can find a career with more than Int +30 and WP +30 on the advance scheme. Since there is no such career in the rulebook, this is impossible at present, but who knows, there might be a super-powerful career published at some time with the right advance scheme.

Scores of 70 in personal characteristics are approaching the human maximum anyway - if you look at the monsters which have higher Int and WP scores, you will find that they are things such as Liches and Demons, which one might expect to have super-human intelligence and strength of will.

Neil Fordham, Great Dunmow: I have an Elven Bounty Hunter who is about to finish his career. I want him to become an Assassin, but I am worried about having to take an alignment change, as the patron of Assassins in Khaine, who is evil - and surely this means that all Assassins are evil.

Although most of Khaine's followers are Assassins, not all Assassins have to follow him. Even so, your GM may decide to make your character change alignment for switching to this career. If your character follows Liadriel (or any other Good deity), he might begin to incur divine displeasure. This is something you will have to discuss with your GM.

Andrew Meecham, Alloa: Can you reduce a character's Insanity Points score in any way? By spending Fate Points or Experience Points, for example?

Insanity Points are very hard to get rid of. Fate Points certainly won't do the trick (Indiana Jones certainly isn't short of Fate Points, but can he get rid of his fear of snakes?), and Experience Points don't work that way at all. Basically, you have to wait until a character's Insanity Points total reaches 6 - then the character gains a disorder, and the total resets to zero. Before that, there is nothing there to treat. Then, of course, you can seek out a Surgeon with a hot wire and a steady hand, or a Pharmacist with the right drugs, or try any of the other cures on p87 of the rulebook.



REALM OF CHAOS

SLAVES TO DARKNESS

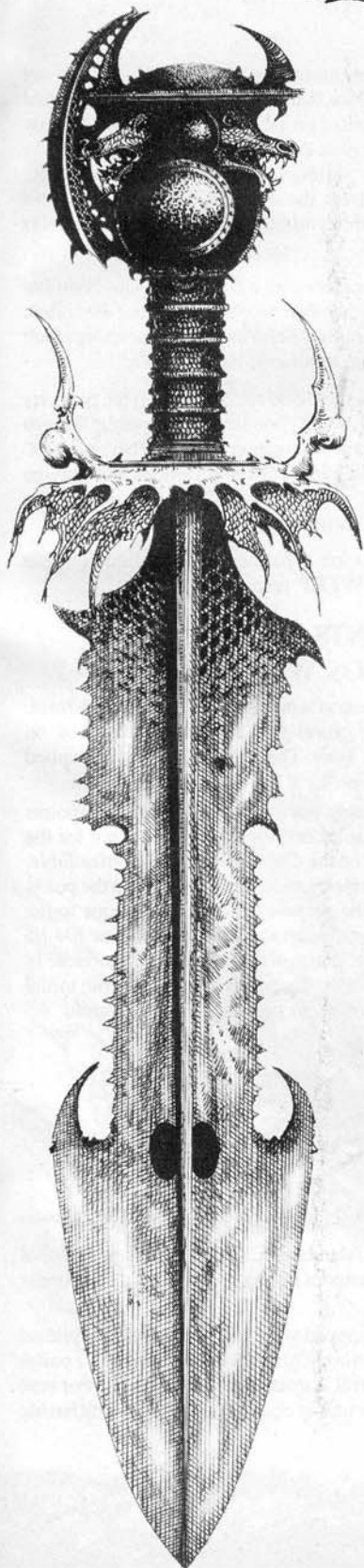

Far beneath Khorne's brazen throne, ringed by moats of burning blood, lie his War Forges. There despair is tempered into steel, hatred into iron, death into a sword's shape... His blinded, crippled mage-smiths labour at the furnace doors and feed the flames when they fall... And from his horrid smithies come blades fair and foul, bright and dark, greater and lesser. But all are attainted, marked and corrupted by Chaos. The wise and prudent man goes unarmed, even into the battle's heart, rather than touch such a blade...

- Ye Describ'd Werkes of Chaos, from a fair copy in the Monastery of Gottschalk

When foul murder is committed, who is guilty? The sword or the man who wields it? In the darkness that is Chaos, who can say?

- Magistorum Chaotica

From the pages of *Realm of Chaos*: the system for generating the Weapons of Chaos. The Screaming swords, the Warp blades, the Vampire axes - all are here presented for your interest, education and delight... Read on, but guard your back...

by Mike Brunton and Bryan Ansell

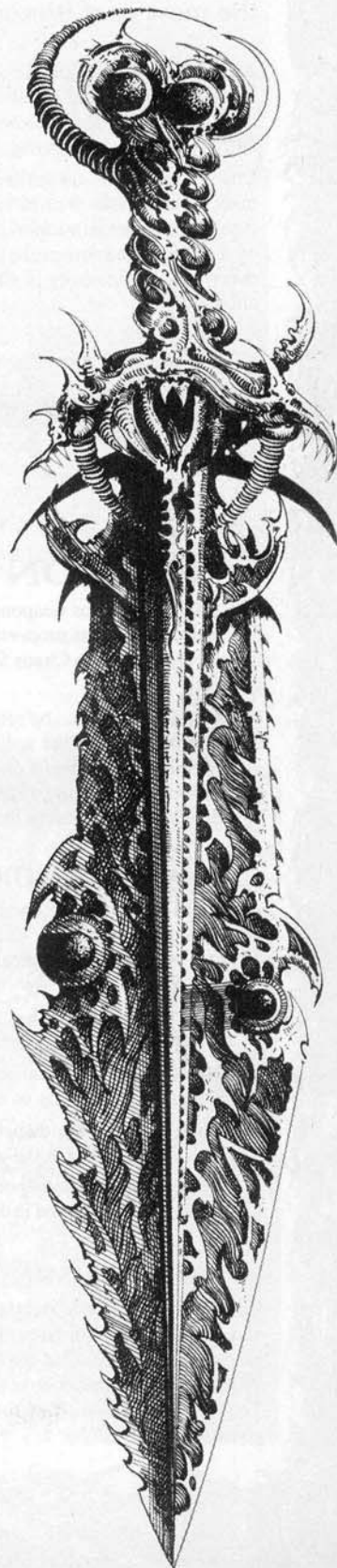

CHAOS WEAPONS

Followers and Daemons of Chaos can use two types of magical weaponry: *Chaos Weapons* and *Daemon Weapons*.

Chaos weapons have relatively limited magical powers which are part of the blade of the weapon. These are determined randomly for each blade. While a weapon generated using the system presented in this section can be quite powerful, for the most part it modifies the abilities and skills of its bearer.

A Daemon weapon, on the other hand, has abilities and powers of its own, based on the Daemon that is bound within the blade. The rules for generating such weapons can be found under *Daemon Weapons* (see the forthcoming *Realm of Chaos - Slaves to Darkness*).

Chaos weapons are always hand weapons of some type: swords, axes, maces and the like. The rules presented here can be applied to any type of close combat weapon, not to missile weapons. While the shape of a Chaos weapon makes no difference to its function, the overwhelming majority of such weapons are swords of one type or another.

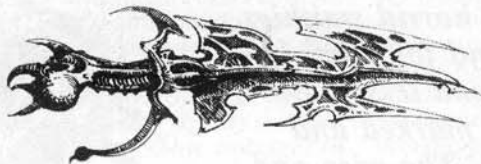

WEAPON PROPERTIES

The abilities of Chaos weapons generated using the system presented here are referred to as *properties*. This title distinguishes them from the powers granted to Chaos followers in the shape of *attributes* and *gifts*.

Followers of Chaos can be affected by the *properties* of a blade that they carry, to almost the same degree as their own *attributes* and *gifts*. While the effects of a *property* last only as long as the creature in question is holding the weapon, in most battles the practical result of a *property* is similar to that of a permanent *attribute* or *gift*.

COMMON PROPERTIES

All Chaos weapons have certain qualities in common, regardless of their individual properties. These common properties are not the same as those of 'ordinary' magical weapons described in *Warhammer Fantasy Battle*.

- 1 Every Chaos weapon has a magical aura which is immediately obvious to any Wizard who touches it.
- 2 Chaos weapons can cause damage to creatures listed as being immune to the effects of normal weapons.
- 3 Chaos weapons can dispel any *Aura* on contact. Roll a D6; on a roll of 3, 4, 5 or 6 the *Aura* is negated.
- 4 The effects of Chaos weapons cannot be avoided by *Magical Saving Throws*, except as noted in the descriptions of individual properties.

DETERMINING PROPERTIES

Warhammer Fantasy Battle allows players to choose the powers of a magical weapon from a list. Chaos weapons, however, are generated randomly, using the *Chaos Weapons Properties Table* below. Players have no direct control over the powers of a particular weapon. The followers of Chaos have to take whatever is produced in the patron god's Forges.

A Chaos weapon may have any number of *properties*, but it may not have a particular *property* more than once. Any duplicates should be re-rolled until an *unduplicated* property is determined. The only limit on the number of *properties* that a weapon may possess is the points cost that the player is willing to pay for a particular blade. Players have no influence over the *nature* of a given weapon's *properties*; they can only determine the *number* of *properties* possessed.

The *Chaos Weapon Properties Table* uses a D1000 roll. This is similar to a D100, except that *three* (rather than two) ten-sided dice are rolled: one for the hundreds, one for the tens and one for the units. A result of '000' is always read as one thousand, never as zero.

In most cases variable powers should be rolled up when the *property* is determined. However, any 'to hit' bonuses and variable *Wounds* are randomly generated each time the weapon is used. Where a 'target' or 'victim' is referred to in the *properties* descriptions this may be an individual or a unit/group. A *property* used against a unit/group may only affect those of its number who are within range.

Where numbers or dice rolls are separated by an oblique (/), the references are to *WFB* and *WFRP* respectively.

POINTS COST OF CHAOS WEAPONS

The points value of a Chaos weapon is not directly related to its powers. Each Chaos weapon costs 25 points *plus* 50 points per die roll on the *Chaos Weapon Properties Table*. The points cost is not multiplied by the character level modifier.

While individual *properties* may not seem to be 'worth' 50 points (or might seem to be worth far more), the points cost is not for the *property* itself. It is for the roll on the *Chaos Weapon Properties Table*. The nature of the generated *property* makes no difference to the points cost of the weapon, even if the *property* is disadvantageous to the bearer of the weapon. A *property*, such as *705-717 Random* or *104-116 Coward*, requires one or more 'extra' *properties* to be generated. In this case the cost is still 50 points; the points are paid for the initial die roll, not the *Coward* or *Random* *property* of the weapon.

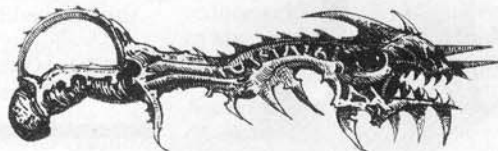

CHAOS WEAPONS FOR UNITS

Units can be equipped with 'standard' Chaos weapons at a cost of 25 points per model. These weapons have only the powers listed under *Common Properties* above.

If you wish, units may be equipped with weapons having additional randomly determined *properties*. This costs an additional 50 points per model, but only one die roll is made for the entire unit. For ease of play it is assumed that the unit is equipped with weapons having identical *properties*.

CHAOS WEAPON PROPERTIES TABLE

D1000 Sword Property

- 001-013 Animation
- 014-026 Banishment
- 027-039 Bewitched
- 040-052 Breathe
- 053-064 Chainsword
- 065-077 Chill Blast
- 078-090 Command
- 091-103 Cool
- 104-116 Coward
- 117-128 Creature
- 129-141 Damage
- 142-154 Deathdealer
- 155-167 Deathlust
- 168-180 Deflection
- 181-192 Degeneration
- 193-205 Disenchantment
- 206-218 Double Damage
- 219-231 Enchanted
- 232-244 Enfeeble
- 245-256 Entrancing
- 257-269 Fade
- 270-282 Fear
- 283-295 Ferocity
- 296-308 Fiery Blast
- 309-320 Flame
- 321-333 Flight

D1000 Sword Property

- 334-346 Freeze
- 347-359 Frenetic
- 360-372 Glittering
- 373-384 Hacking
- 385-397 Hate
- 398-410 Howling
- 411-423 Hurling
- 424-436 Illusion
- 437-448 Immunity
- 449-461 Impunity
- 462-474 Intelligence
- 475-487 Lashing
- 488-500 Leadership
- 501-512 Levitation
- 513-525 Magic Absorption
- 526-538 Magic Destroyer
- 539-551 Magic Force
- 552-564 Magic Reflection
- 565-576 Magic Thief
- 577-589 Might
- 590-602 Mighty Strike
- 603-615 Mindeater
- 616-628 Non-flammability
- 629-640 Parry
- 641-653 Piercing
- 654-666 Plague

D1000 Sword Property

- 667-679 Poisonous
- 680-692 Powersword
- 693-704 Protection
- 705-717 Random
- 718-730 Relic
- 731-743 Resilience
- 744-756 Riposte
- 757-768 Sanctity
- 769-781 Savagery
- 782-794 Screaming
- 795-807 Shrieking
- 808-820 Singing
- 821-833 Skeleton Horde
- 834-846 Skeleton Summoning
- 847-859 Slacken
- 860-872 Sleep
- 873-885 Spell
- 886-897 Stealing
- 898-910 Strength
- 911-923 Swiftswiftness
- 924-936 Warp
- 937-949 Warrior Summoning
- 950-962 Weaken
- 963-975 Will
- 976-988 Wounding
- 989-000 Vampire

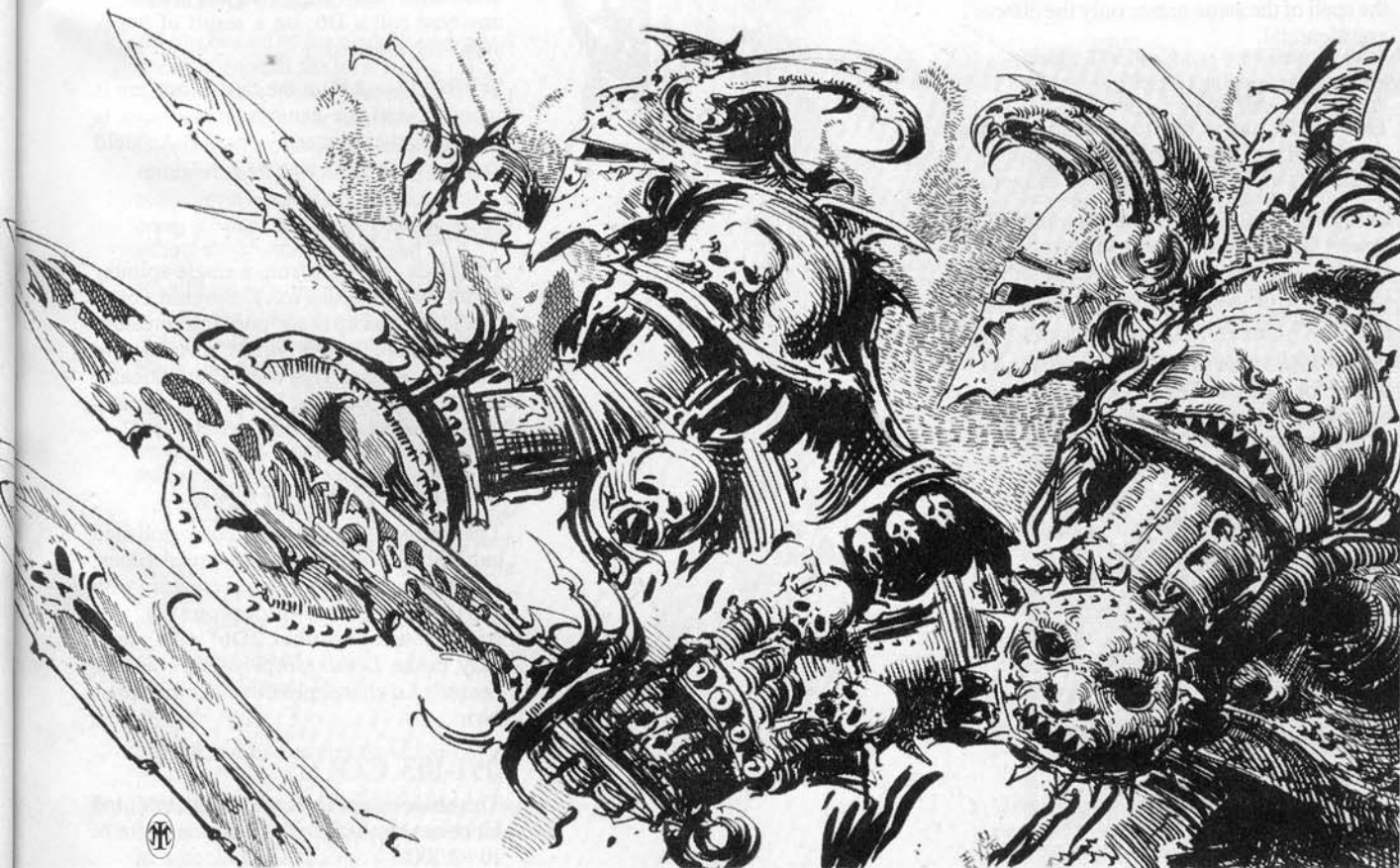

CHAOS WEAPON PROPERTY DESCRIPTIONS

The term *blade* is used in the following descriptions because the majority of Chaos weapons are swords. The *properties* described below can be applied to other close combat weapons if, for example, your favourite model is equipped with an axe rather than a sword.

001-013 ANIMATION

The blade may move and fight on its own, swimming through the air to reach its opponents.

It must remain within 2D6"/4D6 yards of its bearer at all times. It need not be in sight while operating on its own. The blade has the following profile when fighting independently: M4, WS4/41, S4, T4, W3/I7, A3 and I6/60

014-026 BANISHMENT

The blade has been forged over a fire of burning bones and tempered in the blood of a necromancer.

This process gives the bearer the ability to use the equivalent of one Daemonic or Necromantic *Dispel*... of Magic Level D4 or below once per battle (WFRP: once per 24 hour period). This does not cost the bearer any *Magic Points*, or count as using the spell of the same name; only the effects are identical.

027-039 BEWITCHED

The blade has a malicious and evil personality of its own, and delights in leading its unworthy bearers into danger.

Roll 2D6/2D10+40 to determine its *Will Power*. At the start of each turn roll two D6/D10, one for the blade and the other for the bearer, and add the die roll to the respective *Will Power*.

If the blade's total is higher, it controls its bearer for the turn. The model is given the opposing player or the GM for the

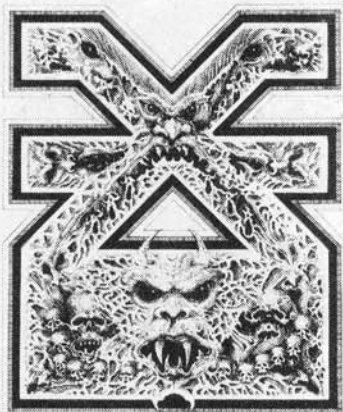
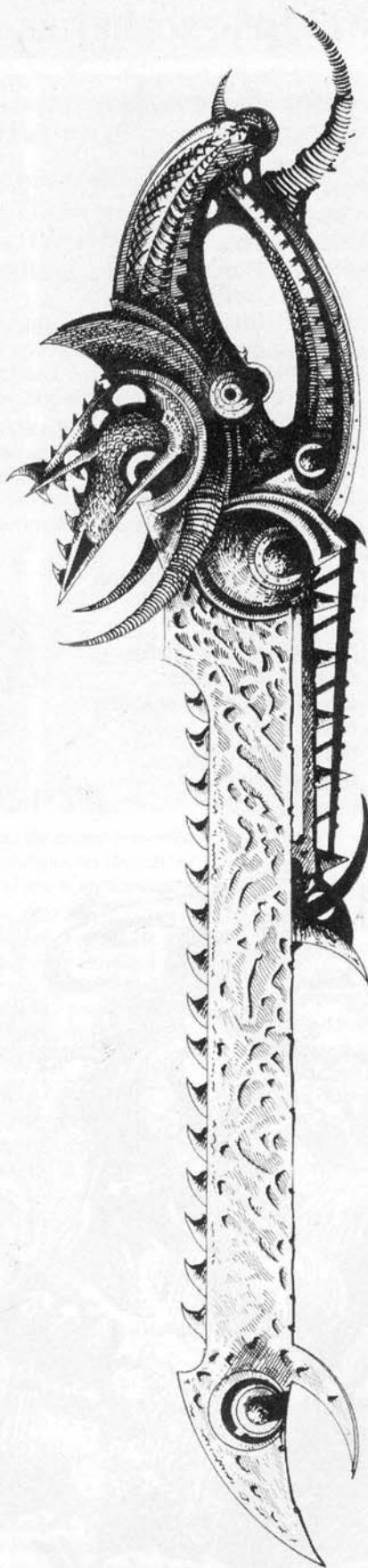

remainder of the turn. They are free to use any of the powers or abilities of the bearer and the sword in any way they see fit.

On any other result the bearer controls his blade and may use it normally during the turn.

Roll again on this table to determine a second *property* for this blade.

040-052 BREATHE

The blade has a scaled surface and a sharkskin hilt. It grants its bearer the ability to breathe safely, even underwater. As a result the bearer is immune to all gas and similar attack forms including, for example, the *musk* of a Fiend of Slaanesh.

053-064 CHAINWORD

The blade is a whirling machine of death and destruction, powered by some arcane and oily (if somewhat noisy) technology.

All attacks made with the blade have *Strength* 4 (rather than using the bearer's S), and cause one *Wound*. The opponent's *Saving Throw* is subject to a -1 penalty.

If the target's save is successful its armour is reduced in effectiveness. It has a -1 penalty to all saves from now on; ie a save of 5 or 6 becomes a save of 6. Alternatively, a non-magical shield (if the target has one) may be destroyed.

If the target is wearing magical armour of any type roll a D6; on a result of 6 it is similarly affected.

WFRP: One AP on the target location is ignored, and the armour in that area is permanently reduced by one AP. A shield may be destroyed instead.

065-077 CHILL BLAST

The blade is forged from a single splinter of eternal, unmelting ice. It can emit a blast of cold from its tip at any one target creature within 2D6"/4D6 yards during the *Shooting Phase*. This blast automatically hits its target, causing D3 S4 hits. Against undead targets the hits are only at S2.

078-090 COMMAND

The weapon is a magnificently polished battleblade, inscribed with dread runes, and the bearer is obviously a creature with a truly commanding personality. All friendly troops within 2D6"/4D6 yards may make *Leadership* rolls using the bearer's Ld characteristic rather than their own.

091-103 COOL

The blade increases its bearer's *Cool* (and CI bonus) by 1/10 each, to a maximum of 10+3/100.

104-116 COWARD

The blade was flawed in its forging and appears discoloured and corroded. It will refuse to fight, unless the bearer makes a successful *Will Power* test at the start of the battle. If the bearer fails in this test he is not allowed to make any *weapon* attacks during the subsequent fighting.

Roll again on this table to determine a second *property* for this blade.

117-128 CREATURE

The blade has the mind and will of some creature bound into it. Often the creature has been used to quench the blade during its forging. As a result the blade has certain additional powers, depending upon the creature used in its construction.

Roll a D20 and consult the table below for the *properties* of the Creature blade:

D20	Blade type
1-2	Cockatrice
3-5	Dragon
6-8	Minotaur
9-11	Skeleton
12-14	Spider
15-17	Troll
18-20	Wraith

Cockatrice: The blade has been forged from the warped and solidified tail of a Cockatrice, and its pommel is made from the skull of the same beast.

All hits caused by the blade do no normal damage. Instead the target must make a *Magic Saving Throw/Magic* test. If this is failed the target is petrified and slain. Creatures over 10 feet tall should not be removed from the battlefield, but left in place as an obstacle to the movement of other models. The blade also causes *fear* in creatures under 10 feet tall.

Finally, on a result of 4, 5 or 6 on the roll of a D6 the blade also confers the power of flight, with the same profile as a Dragon blade (below).

Dragon: This blade has been carved and beaten from a single scale of a Dragon, tempered in the Dragon's spittle.

The blade can breathe fire, with a range of 3D6", causing 1D6 automatic hits, each of *Strength* 4 (5 against flammable targets). The blade also allows its bearer to fly with the following profile:

Maximum Speed: 4D6"
 Minimum Speed: D4-1"
 Acc/dec: D6"

WFRP: the bearer may fly as a *swooper*.

Minotaur: The blade has been forged on an anvil of Minotaur skulls, and quenched in a pool of blood.



The blade penetrates armour easily, and opponent's have a -1 penalty to any *Saving Throws*.

The bearer of the sword is subject to *blood-greed*. After any opponent has been routed or killed the bearer must make a *Cool* test or fall upon the bodies of the fallen and feast for the remainder of the turn. The bearer can do nothing else while eating the dead. This *Cool* test is repeated at the start of every subsequent turn. Only when it is successful does the bearer's feast come to an end.

Skeleton: The blade has been forged from a fused Human vertebrae, bound into a single mass by arcane sorceries. It is edged with the teeth of innocents.

The blade causes *fear* in all living creatures, although those with T7 or more have a +2 bonus on the test.

The bearer of the sword is immune to all psychological effects, and *poisonous attacks* do not receive a normal +1 bonus to their *Strength*.

Spider: The blade has been quenched in the venom of thousand spiders, and bound with silk during its repeated temperings.

The blade is *poisonous*, giving a +1 *Strength* bonus, and a -1 penalty to any *Saving Throw* made by a target.

The bearer is immune to all psychological effects but, if attacked by fire or within 4"/8 yards of a fire he must take a *panic* test.

Troll: The blade has been deeply etched with Troll blood, and its edge repeatedly tested by being thrust into a still living Troll.

The blade can spurt digestive acids over an opponent once per battle. This causes one automatic *Strength* 5 hit, which ignores all armour and causes D3 *Wounds*.

WFRP: the blade can use its power once per 24 hour period. The acid causes D3 *Strength* 10 hits. Armour offers no protection, and non-magical armour and weapons are ruined.

Wraith: The blade has been heated over a fire of grave dust and gibbering souls, and quenched in a living Human.

The blade has an automatic *chill attack*; any hits cause one *Wound*, and no damage roll need be made. A *Saving Throw* is allowed.

WFRP: the blade drains one point of the target's *Strength*. Creatures reduced to zero *Strength* are slain.

The blade also causes *fear* in living creatures.

Other types of Creature blades are possible, and you should feel free to invent your own.

129-141 DAMAGE

The blade causes D4 *Wounds* when it hits the target. No *Saving Throw* is allowed, unless wearing magical or Chaos armour.

WFRP: ignore *Armour Points* (unless magical) and calculate damage caused as normal, then multiply by D4.

142-154 DEATHDEALER

The blade has been partly quenched in the blood and spirit of some creature, giving it a desire to endlessly quench its inner fire in more of the same blood. As a result, the blade can strike down one specific type of creature, destroying its mind and personality as well as its body.

When an appropriate target is hit by the blade it dissolves into a small heap of dust and is instantly slain. Roll a D100 and consult the table below for the type of creature affected:

D100	Result
01-04	Beastmen, including Minotaurs and other sub-varieties of Beastmen
05-08	Creatures of Chaos, including Chaos Spawn
09-12	Daemons. Roll a D6; on a 1, 2, 3 or 4 the blade only has its devastating effect against Lesser Daemons. On any other result it works against all of Daemonkind.
13-16	Dragons
17-20	Dwarfs
21-24	Elementals
25-28	Elves
29-32	Fimir
33-36	Giants
37-40	Gnomes
41-44	Goblins
45-48	Heroes; any creature which has a profile above its standard racial type.
49-52	Humans
53-56	Lizardmen
57-60	Mortal Chaos followers, again including Chaos Spawn.
61-64	Ogres
65-68	Orcs
69-72	Skaven
73-76	Slann
77-80	Trolls
81-84	Undead
85-88	Werecoatles
89-92	Wizards, Sorcerers and other similar spellcasters
93-96	Zoats
97-99	Creatures of a Good Alignment
00	Creatures of a Lawful Alignment

Against other creatures the blade can strike and damage opponents who are immune to non-magical weapons, but has no other properties.

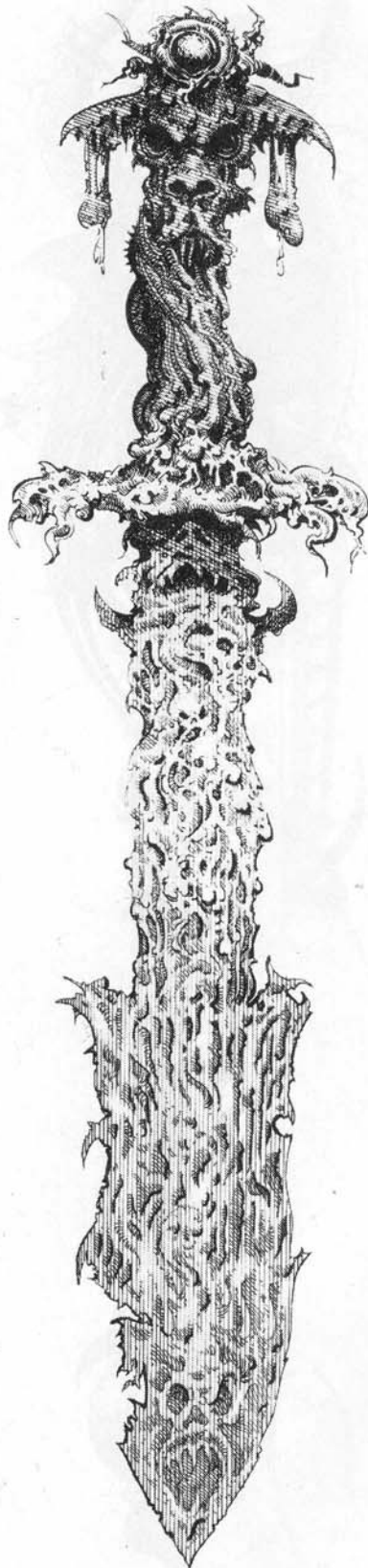

155-167 DEATHLUST

The blade was heated in the fire of a burning heart, and desires only to taste its opponent's heartsblood. It grants the bearer a +1/10 bonus on his 'to damage' rolls when making attacks with the blade.

168-180 DEFLECTION

The blade been forged of light and airy metal, and it allows the bearer to deflect a number of missile attacks equal to his *Weapon Skill* in a single *Missile Phase/Round*.

The decision whether or not to deflect a missile need only be taken after the 'to hit' die has been thrown for the attack.

181-192 DEGENERATION

The blade has a rotten and putrescent appearance, having been forged from corruption and foulness made solid. Whenever it hits an opponent it leaves a little of its substance in the wound.

Any target which takes a *Wound* from this blade must roll a D6 at the start of each following turn (**WFRP:** after D6 rounds). On a result of 6 the victim loses another 1/5 *Wounds*. The *Degeneration* can only be halted by a *Cure Severe Wounds* spell.

Victims of this property can be indicated by a small marker placed next to the figure.

193-205 DISENCHANTMENT

The blade is a bane to all magic using creatures, tipped with runes and arcane symbols.

The blade reduces its target's *Magic Points* (if any) or *Daemonic Power Points* by D6 each time it hits. No *Wound* need be caused, but the target may make an *Armour Saving Throw* against the blade's effect.

Drained *Magic Points* may be added to those of the bearer.

206-218 DOUBLE DAMAGE

The blade has been magically sharpened, and enchanted so that it twists and turns within a wound.

Each hit caused by this blade allows two rolls on the *Damage Chart* (**WFB** p54).

WFRP: roll a D6 twice for damage, adding the bearer's *Strength* to, and subtracting the target's *Toughness* from, each die roll.

219-231 ENCHANTED

The blade is enchanted and finely made, carved with runes along its spine and etched with scenes of battle. It can strike and damage opponents who are immune to non-magical weapons but has no other properties.

232-244 ENFEEBLE

The blade reduces its target's *Toughness* by one each time it hits. No *Wound* need be caused, but the target may make an *Armour Saving Throw* to avoid the blade's effect. If *Toughness* is reduced to zero the target is dead.

245-256 ENTRANCING

The blade has been polished to a impossibly bright finish and now has a dazzling and hypnotic effect. All enemy models within D6"/2D6 yards of the blade's bearer are subject to *stupidity* unless they can make **WP** tests to avoid looking at it. *Will Power* tests must be made at the start of every turn to avoid or escape the blade's entrancing effect.

257-269 FADE

The blade is made from grey metal, which appears to dissolve at times into no more than a wisp of smoke or mist.

It causes those it strikes to become insubstantial and eventually fade away. Whenever the blade hits, reduce all the target's characteristics by one (**WFRP**: five in the case of percentage characteristics). At the start of each subsequent turn roll a D6; on a result of 4, 5 or 6 the target's characteristics are reduced again by a similar amount.

As this fading continues the victim becomes increasingly nonexistent and loses touch with reality. As a result 'reality' can affect the victim only to a lesser degree and all the victim's saves receive a +1/10 bonus. This is increased by 1/10 for each time that fading has occurred.

When any one characteristic drops to zero or below the victim fades completely and vanishes, washed out of reality into the never-ending void of Chaos.

Victims of the blade's fading *property* can be indicated by a small marker placed next to the figure.

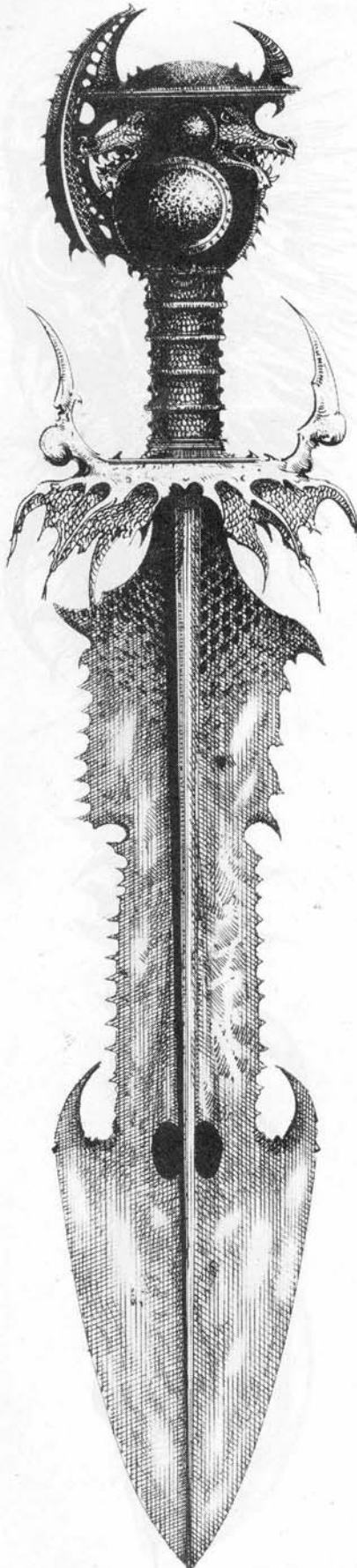

270-282 FEAR

The blade is subject to *fear* of one group of creatures, which it passes on to its bearer. In addition, when it is in combat against such creatures, no *weapon* attacks are possible, although the bearer may use other attack forms (if any).

Roll a D100 and consult the table below to determine the object of the blade's *fear*:

D100	Result
01-04	Beastmen, including Minotaurs and other sub-varieties of Beastmen
05-08	Creatures of Chaos, including Chaos Spawn.
09-12	Daemons. Roll a D6; on a 6 the blade <i>fears</i> all Chaos Daemons. On any other result it <i>fears</i> the Daemons of the opposing Power of Chaos; eg Khorne blades <i>fear</i> all the Daemons of Slaanesh.
13-16	Dragons
17-20	Dwarfs
21-24	Elementals
25-28	Elves
29-32	Fimir
33-36	Giants
37-40	Gnomes
41-44	Goblins
45-48	Heroes. Any creature which has a profile above its standard racial type.
49-52	Humans
53-56	Lizardmen
57-60	Mortal Chaos followers. Roll a D6; on a 6 the blade <i>fears</i> all Chaos followers. On any other result it <i>fears</i> the followers of the opposing Chaos power; eg a Slaaneshi blade <i>fears</i> Khorne's mortal followers.
61-64	Ogres
65-68	Orcs
69-72	Skaven
73-76	Slann
77-80	Trolls
81-84	Undead
85-88	Werecoatres
89-92	Wizards, Sorcerers and other similar spellcasters
93-96	Zoats
97-99	Creatures of a Good Alignment
00	Creatures of a Lawful Alignment

Providing it does not fear them, the blade can strike opponents who are immune to non-magical weapons.

283-295 FEROCITY

The blade is forged from the armour of a fallen Champion of Chaos and allows its bearer to make an extra *weapon Attack* (bearer's A+1).

296-308 FIERY BLAST

The blade has been forged from a single flame, bound into a flickering blade of black iron. It can emit a fiery blast from its tip at any one target creature within 2D6"/4D6 yards during the *Shooting Phase*. This blast automatically hits its target, causing D3 S3 hits. Against flammable targets the *Strength* of the blast is increased to four. No *Saving Throw* for armour is allowed.

WFRP: *Armour Points* are ignored.

309-320 FLAME

Never having been quenched, the blade has been enchanted to retain the heat of its forging. It bursts into flame when drawn, causing *panic* in some creatures (ie those listed as subject to *panic* in the presence of fire - wolves, for example). It has a +1 *Strength* bonus against flammable targets.

321-333 FLIGHT

The blade's hilt or handle is carved from swan's bones and it allows its bearer to fly with the following profile:

Maximum Speed: 4D6"
Minimum Speed: D4-1"
Acc/dec: D6"

WFRP: the bearer may fly as a *swooper*.

WH40K: Turn Radius Ratio: 1.

334-346 FREEZE

This blade of jagged and splintered steel has been forged on an anvil of ice, unheated in an unflame of frost and quenched in a pool of fire. Roll a D6 when a living creature suffers damage from a blow made with this blade. On a roll of 2 or more the victim is automatically killed. The victim is not entitled to a *Saving Throw*.

347-359 FRENETIC

The blade allows the bearer to use his *Weapon Skill* as the number of *Attacks* he can make with it. The first of these attacks is made with the bearer's *WS*, but subsequent attacks are made with a

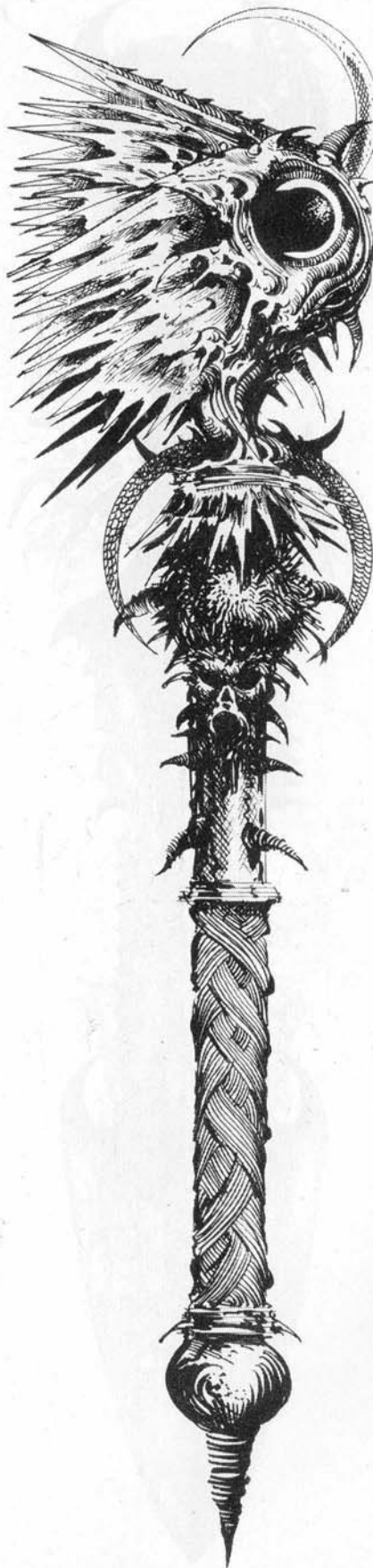
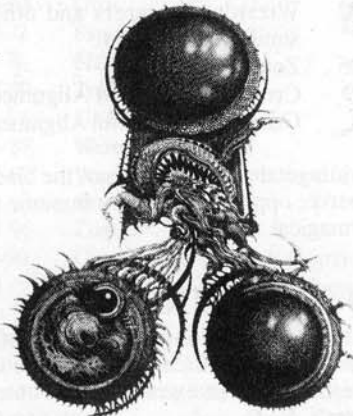

cumulative -1/-10 penalty to the bearer's *Weapon Skill*; ie the first attack is at the bearer's full *WS*, the second at *WS-1/-10*, the third at *WS-2/-20*, the fourth at *WS-3/-30*, etc.

360-372 GLITTERING

The blade has been magically polished to a perfect finish, and the dazzling reflections it causes reduce any opponents' *Weapon Skill* by D4/D4x8, to a minimum of one.

373-384 HACKING

The blade has a jagged edge, and has been enchanted so that it repeatedly lunges in and out of wounds. As a result it causes D6 *Wounds* to living creatures.

WFRP: calculate damage in the normal way, then multiply by D6.

385-397 HATE

The blade has been forged upon mind and soul of a creature, and is now subject to *hatred* of that type of beast. It passes this irrational feeling on to its bearer.

Roll a D100 and consult the table given under 270-282 *Fear* (above) to determine the subject of the blade's *hatred*. Treat all references to *fear* on that table as references to *hatred*. When used against such creatures it grants *two* attacks for every one *weapon* attack the bearer would normally be able to use.

Providing it does not *hate* them, the blade can strike opponents who are immune to non-magical weapons. It has no other properties.

398-410 HOWLING

The blade emits a dirge-like and unearthly howling, which is deeply disheartening to any enemies unfortunate enough to hear it. All living enemy creatures within 6"/12 yards are subject to *fear*.

The sword of the Knight of Chaos was placed upon the anvil, and the smith rained many mighty blows upon it, and yet no mark did show upon the blade. It was thrust into the heart of the furnace, and when it was brought forth, the smith did smite the blade once more with all the skill of his craft, now upon the flat, and now upon the edge, and still no

411-423 HURLING

The blade may be hurled at an opponent up to 2D6"/4D6 yards away during the *Shooting Phase* using the bearer's *Ballistic Skill* and *Strength*.

If the attack is successful the blade automatically returns to its bearer's hand. If the attack misses (ie the 'to hit' roll is a failure) the target may catch the blade by making an *Initiative* test. The target can then use the blade on subsequent turns.

424-436 ILLUSION

The blade is carved with runes and its pommel is made from the skull of an Illusionist. Its bearer is granted an illusionary appearance which hides his true nature. A completely different (even inappropriate) model may be substituted for the bearer's model on the table top.

Any psychological effects caused by the bearer are ignored until the blade is used in combat. The sham appearance is then dropped for the remainder of the battle.

437-448 IMMUNITY

The blade has been quenched in the blood of brave and noble men, and increases its bearer's *Toughness* by +D3, up to a maximum of 10.

449-461 IMPUNITY

The blade's pommel and hilt are made from the still-living heart and ribs of a failed servant of the Chaos gods. The blade increases its bearer's *Wounds* by 1/5.

462-474 INTELLIGENCE

The blade has been forged between two scholarly skulls, and tempered in flames of burning books of forbidden lore. It increases its bearer's *Intelligence* (and *Int* bonus) by 1/10 each, to a maximum of 10+3/100.

mark did show upon the blade. My scribe did chance to prick himself upon his small knife, and but a single drop of blood fell on the anvil, onto the cursed blade that lay there. At this a great rune shone forth, redder than the heart's blood, and darker than night. The evil sword did pulse and sing upon the anvil, and all fled in fear of the dire thing.

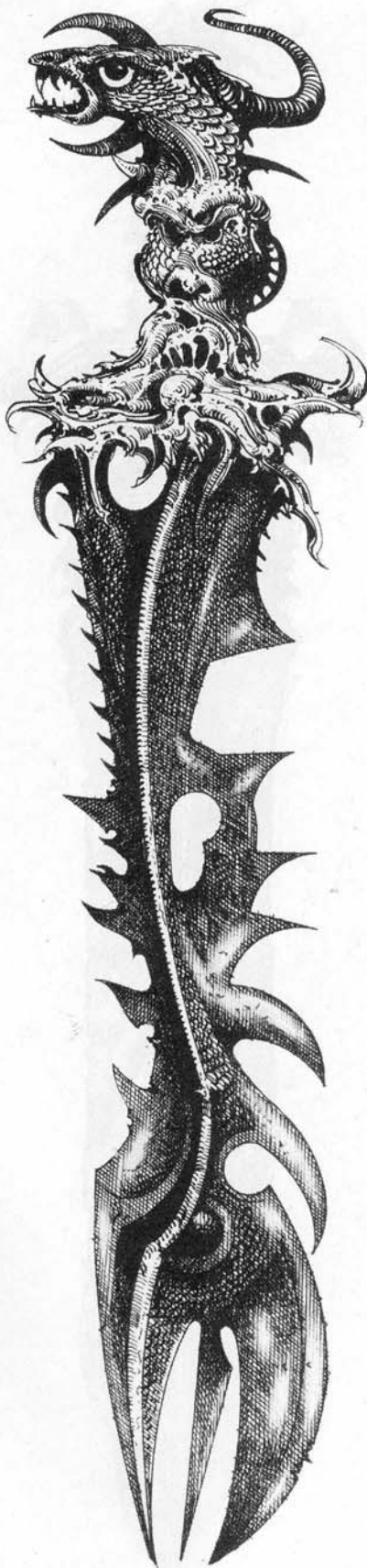

475-487 LASHING

The blade is cast from living metal, and cunningly wrought into the form of a snake or tongue. It may be used to attack an opponent up to 2D6"/4D6 yards away during the *Hand to Hand Combat Phase*. The blade lashes out to its full extent, makes an attack, and then returns to its original length and shape.

The target is entitled to make an *Armour Saving Throw* against the blade's attack, but cannot attack the bearer, unless allowed to do so by his own magic blade or a suitable *Chaos* attribute.

488-500 LEADERSHIP

The blade has the undying spirit of a mighty mortal warrior bound within it. As a result it increases its bearer's *Leadership* (and *Ld* bonus) by 1/10 each, to a maximum of 10+3/100.

501-512 LEVITATION

The blade is suffused with magical power and the ashes of a mutant with the power of levitation. It allows its bearer to float up or down D6"/2D6 yards per turn, but confers no power of sideways movement.

513-525 MAGIC ABSORPTION

The blade is forged from a wattle-spine of a Fleshhound of Khorne, bound with black iron and brass and quenched in the spittle of a Wizard.

It absorbs any spell cast against its bearer, and the spell therefore has no effect. The spell is, however, retained within the blade, and the bearer may release it (at no cost in *Magic Points*) during a subsequent *Magic Phase*.

Only one spell may be retained within the blade at one time, but a currently held spell may be supplanted by a second spell at the bearer's discretion.



526-538 MAGIC DESTROYER

If this rune-carved blade scores a hit against a creature carrying one or more magical items roll a D6. On a result of 5 or 6 all the magical properties of one of the target's magical items are destroyed. If the target has more than one item randomly determine the object which is affected.

539-551 MAGIC FORCE

The blade (a forcesword) pulses with power and is highly attuned to the flow of magical energy. The bearer can expend *Magic Points* (if he has any) to increase the strength of a blow from the sword. Each *Magic Point* expended adds +1 to the *Strength* of the blow, and also reduces the target's *Saving Throw* by -1.

552-564 MAGIC REFLECTION

To the uneducated eye the blade is crudely made, poorly finished and rusty. To any form of magical power it is, however, the most perfect of mirrors.

The blade can reflect any spell cast at its bearer back at the Wizard who cast it. The spell is only reflected back if the bearer manages to roll under his *Weapon Skill* on 2D6. The spellcaster suffers the full effects of a reflected spell, although he is entitled to a *Magic Saving Throw* if this is normally the case.

565-576 MAGIC THIEF

If a hit is scored against a creature carrying a magical object this blade can steal the *properties* of the target's magic item. Roll a D6; on a result of 5 or 6 the blade drains all powers from the target item, but those same powers pass into the blade for the remainder of the battle (WFRP: 24 hours), and may be used by the bearer. If the target has more than one item, randomly determine the object which is affected.

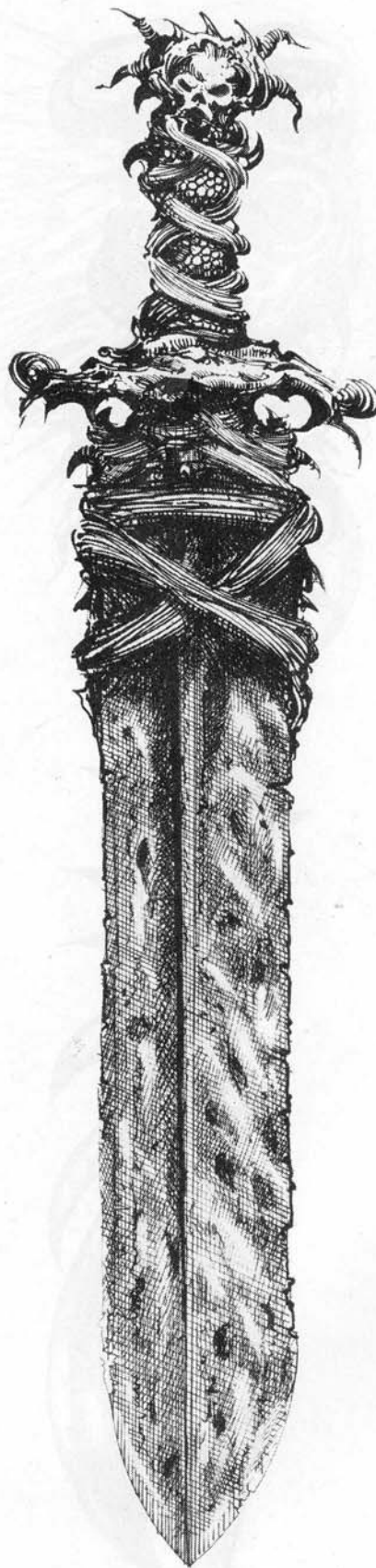

577-589 MIGHT

The blood-red blade pulses with a life of its own, and bleeds whenever it is parried. However, the bearer's *Strength* is increased by three when making attacks with this blade. The *Strength* of any other attacks made by the bearer is unaffected.

590-602 MIGHTY STRIKE

This dull and unsharpened blade is forged from a single rib-bone of a Daemon (Greater or Lesser).

It allows the bearer to make one S10 hit during a single battle (WFRP: within a 24 hour period). The bearer decides to use this ability after he has actually hit a target but armour is taken into account.

603-615 MINDEATER

This bone-like blade has an insatiable hunger for the thoughts and feelings of those it hits.

The blade causes no physical damage when it hits a target, ie no *Wounds* are inflicted. Instead the target's *Ld*, *Int*, *Cl* and *WP* are reduced to zero.

The target becomes subject to *Stupidity* immediately, and loses all skills.

616-628 NON-FLAMMABILITY

The blade has a hilt and pommel carved out of solidified tears from a writhing victim of the Chaos fires and tormenting Daemons.

It confers on its bearer an immunity to all fire based attacks, including *Fire Ball* spells, and *Dragon breath*.

629-640 PARRY

The blade has been created by a weapon master. It may automatically stop one or more opponents' attacks from hitting its bearer. The decision whether or not to parry a blow need only be taken after the 'to hit' die has been thrown for the attack.

For each blow that is parried the blade 'uses' one of its bearer's *Attacks*. An *Attack* which has been used to make a parry cannot be used as an attack during the same *Hand-to-hand Combat Phase*.

641-653 PIERCING

The blade hungers for the lifeblood of its opponents, and refuses to be deflected from this purpose.

Creatures wearing non-magical armour have no *Saving Throw* against any damage caused by this unnaturally sharp blade.

654-666 PLAGUE

The blade is infected with a hideous Chaos-warped disease. During its forging, tempering and quenching, diseased mutants were used to test the blade's edge, and its metal is tainted as a result.

Blades originally received by Nurgle's followers are infected with *Nurgle's Rot*. For blades of other Chaos Powers roll a D6 and consult the following table to determine the Plague blade's effects. Whenever the blade hits an opponent in hand to hand combat it may pass on its infection. No damage need have been caused by the blade. The target makes a *Toughness* test, and if this is failed the effects of the plague are applied immediately.

D6 Plague

1 The Shakes

The plague causes terrible shaking fits, so that its victim can no longer control muscles and limbs properly. Reduce **WS** by 1/10 and **A** by 1.

2 Eye Rot

The plague causes the victim's eyes to swell and distend, growing large and bulbous with retained fluid. Reduce the victim's **BS** by 1/10.

3 Creeping Bubos

The plague covers the victim's limbs in foul ulcers and leprous sores. These restrict movement and cause great discomfort. Reduce the victim's *Move* by one, and **I** by 1/10.

4 Bone Ague

The plague changes the victim's bone structure, causing uncontrollable growth in some bones, and a withering inner rot in others. Reduce **S** and **T** by 1 each.

5 Grey Fever

The plague causes the victim's brain to waste and eventually dry out. This, in turn, brings senility and dementia. Reduce the victim's **Int**, **Ld**, **Cl** and **WP** by 1/10 each.

6 Green Pox

The plague causes the victim to break out in hideous green spots and pimples. As the pox takes its toll and the infection spread the victim grows thinner and weaker. Reduce **Wounds** by 1/5.

At the end of every battle (**WFRP**: 24 hours) any survivor with a plague must make a further *Toughness* test. If this is failed the plague effects are applied again. No characteristic can drop below one as the result of one of these plagues.

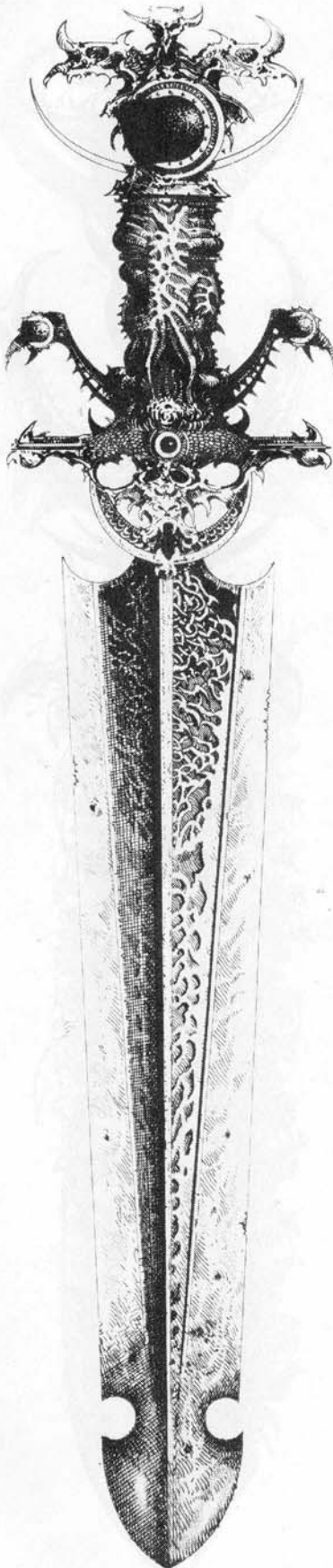

667-679 POISONOUS

The metal of the blade is tainted and venomous as a result of its quenching in poison and bile. Blows struck with this blade have a +1 *Strength* bonus. No *Strength* can be raised above 10 by this blade's *property*.

680-692 POWERSWORD

This blade is a technological and anachronistic marvel: a weapon of pure energy seemingly drawn from the heart of a star. All attacks made with the blade have *Strength* 5 (rather than using the bearer's **S**), and cause one *Wound*. The opponent's *Saving Throw* is subject to a -1 penalty.

WFRP: One **AP** on the target location is ignored.

693-704 PROTECTION

The blade allows its bearer to prevent any one type of creature from moving closer than 3 1/6 yards away from him. The blade's bearer is similarly prevented from moving closer to the prohibited creature.

The creature being banned from the bearer's immediate presence must be of a specific type: Goblin, Skeleton, Daemonette etc. Only one creature type may be held at bay during a single battle (**WFRP**: 24 hours). Such creatures cannot attack the blade's bearer in hand to hand combat, but they can still use missile weapons.

705-717 RANDOM

The blade is highly unstable, tinged with the raw stuff of Chaos and with a pommel of warpstone. Roll six times on this table and note down the results. At the start of each turn (**WFRP**: after D6xD6 rounds) roll a D6 to determine which of its random *properties* the blade manifests. The *property* the blade gives to its bearer is in effect for that turn only, though it may be repeated during the next turn as a result of the next die roll on the *Random* table.



718-730 RELIC

The blade has been made from, or immersed in, the blood or powdered bones of a profoundly good and noble creature.

The blade either confers a +D3 'to hit' or causes D6 *Wounds* (but not both) when used against certain types of creatures (WFRP: calculate damage normally, and then multiply it by D6). The decision as to which of the Relic's *properties* to use can be made by the bearer each time it is used.

Roll a D6; on a result of 1 or 2 the Relic is effective against undead creatures. If the result is 3, 4, 5 or 6 the blade has been made to destroy Daemonkind. The blade will use its *properties* against all types of undead or daemonic beings.

Finally, the blade is incapable of attacking creatures of a Good of Lawful alignment. If the bearer uses it to strike at such a target he will be paralyzed for the remainder of the battle (WFRP: 24 hours).

Against other creatures the Relic can strike and damage opponents who are immune to non-magical weapons but has no other unusual *properties*.

731-743 RESILIENCE

The blade is incredibly strong, made of fine, unflawed metal. It increases its bearer's *Toughness* by 1, to a maximum of 10.

744-756 RIPOSTE

The blade is crafty in all the tricks and techniques of battle, having been crafted by a weapon master who whispered his secrets into the raw metal. It may automatically stop an opponent's attack from hitting its bearer, without using any of its bearer's *Attacks*. The decision whether or not to parry a blow need only be taken after the 'to hit' die has been thrown for the attack.

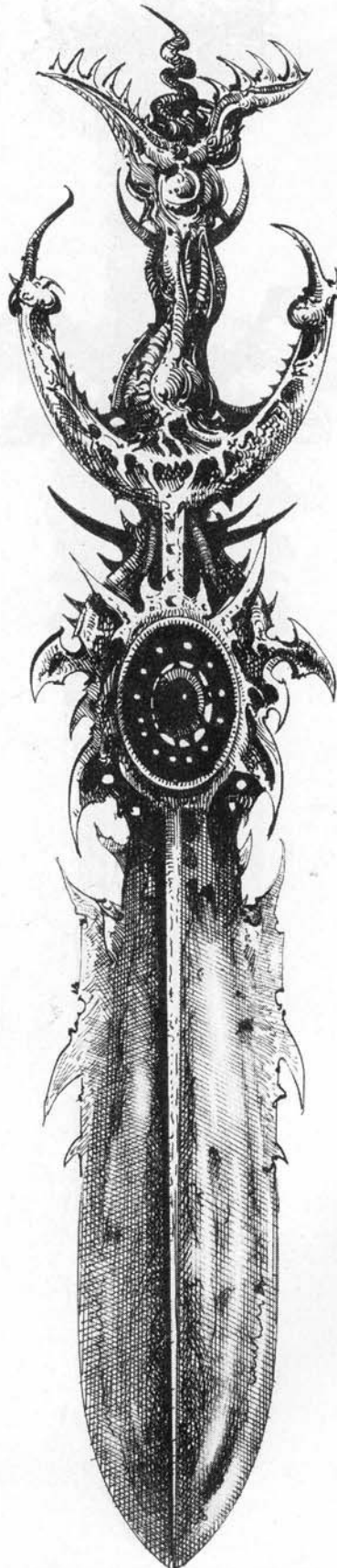

757-768 SANCTITY

The blade has been forged from the despair of those unable to die, and washed in the prayers of those afraid of death. It has great power against undead and ethereal creatures, destroying any within 3"/6 yards at the end of the bearer's *Movement Phase* (WFRP: the current round). Undead heroes may retreat out of range, but if they are unable or unwilling to do so they are also destroyed.

Finally, undead heroes, skeletal Champions of the Chaos and the like, within 12"/24 yards of this blade are aware of its presence and its destructive power. The player controlling such models should be told of the blade's *property* and which model is carrying it.

769-781 SAVAGERY

This bloody-minded blade has been quenched in the blood and soul of a beast or insane Human. The blade grants its bearer an extra D3 *Weapon Attacks* (bearer's A+D3).

782-794 SCREAMING

The blade shrieks a song of hate and despair which unmans any who are within 12"/24 yards. All living enemy creatures who hear its song are subject to *fear +1/Terror*.

795-807 SHRIEKING

The blade has been washed in the tears of young children and women. The bearer can command the blade to voice a terrible keening shriek, which is agonising to all who can hear it. On a turn during which this noise can be heard all living creatures (friends and enemies) within 12" must take a *panic* test.

The bearer is unaffected by the blade's shrieking.

Stand forth, Servant. The Sword you carry has been smelted in the heat of your anger, forged upon your desire, tempered in your hate, quenched in your soul, polished with your loyalty, furnished with your bones and skin, tested in your hand, and borne in my name. You, Slave, are Mine, as much as the Blade...

808-820 SINGING

The blade emits a siren-like song that attracts all enemies who hear it.

Anyone within 12"/24 yards who fails a *Will Power* test must move into base-to-base contact with the bearer (or move as close as possible) and then stand in rapture, listening to the sword's song. Victims who are trapped by the song cannot move, attack or defend themselves.

The song's effects last until the listeners make a successful *WP* test.

821-833 SKELETON HORDE

The blade is bound with necromantic runes and symbols to trap its slain victims in servitude to its bearer.

Each time the blade kills an opponent the model is removed from the table and replaced by a Skeleton. The new skeleton model has a standard profile (see *WFB* p260, *WFRP* p250), and should be placed on the table so as to conform with the rules about unit formations (see *WFB* p44). The blade's bearer is the unit leader, and must be positioned as such. Further models killed by the blade join the unit, but models killed by Skeletons in the bearer's unit do not in turn become Skeletons.

The unit of one or more Skeletons will fight for the blade's bearer for the remainder of the battle (*WFRP*: 24 hours), then crumble into dust.

834-846 SKELETON SUMMONING

The blade is made from fused bones and baked sinew, polished to a razor edge and painted with runes of blood.

Once in every battle the bearer of the blade may summon the souls of those the sword has slain during any *Magic Phase*. A unit of 2D6 Skeletons with standard profiles appears within 3" of the blade's bearer. These skeletons will follow the orders of their summoner for D6 turns/D6xD6 rounds, and then vanish.

Even if the skeletons are destroyed a full complement will appear on the next occasion when they are summoned.

847-859 SLACKEN

The blade has been infused with the essence of a stolen soul of a sleeping old man, and forged upon the back of an indolent youth. It reduces its target's *Initiative* by 1 each time it hits. No *Wound* need be caused, but the target may make a *Saving Throw*. If the target's *Initiative* is reduced to zero it is paralyzed, and can carry out no further actions for the remainder of the battle (*WFRP*: the paralysis is permanent).

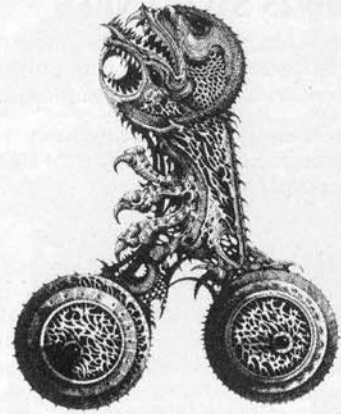
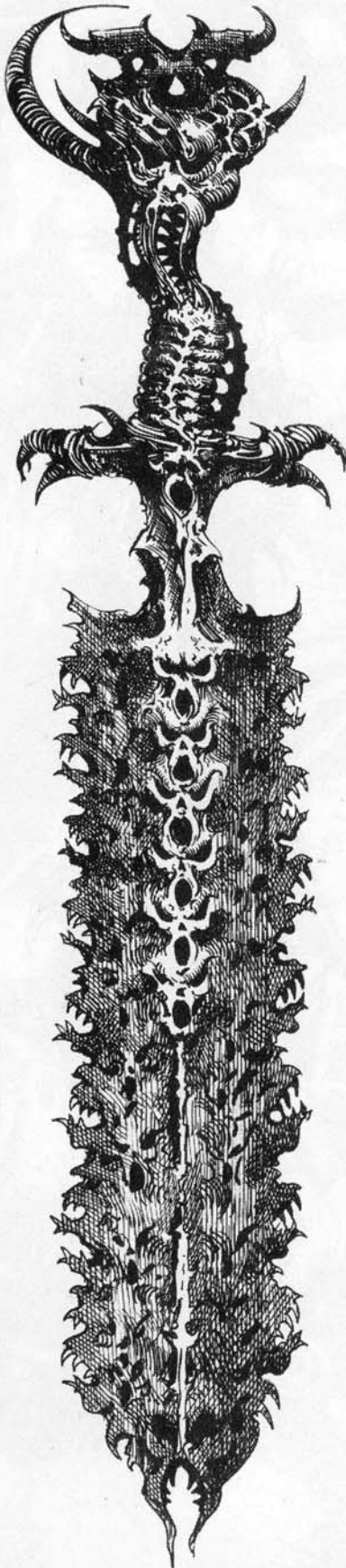
**860-872 SLEEP**

This blade is forged from darkness and the mindless whispers of Daemons. It may cause a single model within 4"/8 yards to 'fall asleep' for D6 turns/D6xD6 rounds. The victim can do nothing but quietly snore for this period, and cannot be awoken.

If the target has an *Intelligence* of 5/18 or more, it is entitled to make a *Will Power* test to avoid falling asleep.

873-885 SPELL

The blade is strangely worked, and has the mind of a Wizard trapped within it. It can cast at least one randomly determined spell. Roll a D4 to determine the *Magic Level* of the most powerful spell the blade can cast. It can also cast one spell of each level below the one generated.

Randomly generate one spell of each level that the blade can use. It can cast each spell once per battle, during any of the bearer's *Magic Phases*. No *Magic Points* are expended to cast these spells.

886-897 STEALING

The blade has been heated over a fire of starving souls, and its edges worked into a thousand tiny mouths, each biting and chomping at the air.

Every time this blade causes a *Wound* the bearer may select a characteristic from the target's profile and reduce it by 1/5. This 'stolen' characteristic value is then added on to the bearer's profile for the remainder of the battle (*WFRP*: 24 hours).

898-910 STRENGTH

The blade pulses with an unclean life of its own, and reverberates with the beating of a heart deep within its foul metal.

Part of its unnatural vitality is passed on to its bearer, whose *Strength* is increased by 1.

911-923 SWIFTNES

The blade is made of the lightest of all metals, pierced through with holes, and carved with airy symbols and runes.

It increases its bearer's *Initiative* by +D10, to a maximum of 10; **WFRP**: +D100, to a maximum of 100.

924-936 WARP

The blade is tainted with the mark of Chaos. Its metal is filled with roiling Chaos-stuff that moves and changes beneath the surface, showing now one distorted reflection and then another.

Each time the blade hits an opponent it induces D3 *Chaos attributes* in its target. No damage need be caused for the blade to have its warping effect, but the target is entitled to a *Saving Throw*.

These should be generated randomly using the *Personal Attributes Table* in *Appendix 1 - The Mark of Chaos*, and the effects applied to the target. This may result in a creature in a unit receiving *personal*, rather than *dominant*, attributes. If this occurs the figure should no longer be treated as part of his unit, but as a separate, minor character model.

If the victim of the blade's warping power is killed by the same stroke there is no need to determine the nature of his final mutations. He simply sprouts tentacles, eye-stalks, extra limbs and the like and then dies.

Use of this *property* for blades can slow down a game considerably while profiles and abilities are modified. You may wish to re-roll on this table for another *property*.

937-949 WARRIOR SUMMONING

The blade has been washed with the blood of many warriors, and quenched in their living hearts. These undying warriors are bound to an eternity of service to this dark blade.

Once during every battle the bearer of the blade may summon the servants of the sword. This can happen during any *Magic Phase*. A group of D6 Humans, with standard profiles and wearing *Chaos Armour* appear within 3"/6 yards of the blade's bearer. They are armed with enchanted blades which, other than being able to hit creatures immune to non-magical weapons, have no special powers. These warriors will serve their summoner for D6 turns/D6xD6 rounds, and then vanish.

Even if the warriors are killed, a full complement of troops will appear next time they are summoned.



950-962 WEAKEN

The blade hungers for the life-force of living creatures, and cannot be satisfied no matter how much it is fed.

It reduces its target's *Strength* by one each time it hits. No *Wound* need be caused, but the target may make a *Saving Throw*. If the target's *Strength* is reduced to zero it dies.

963-975 WILL

The blade was cold-forged and has an unearthly intensity of purpose and will as a result. Its inner fire drives it ever onwards, and drives its bearer in the same manner.

The blade increases its bearer's *Will Power* (and *WP* bonus) by 1/10 each, to a maximum of 10+3/100.

976-988 WOUNDING

The blade writhes within a wound that it causes, drinking in its opponent's suffering as it does so.

Instead of causing only one *Wound*, the blade causes D3 *Wounds* each time it damages an opponent. **WFRP**: calculate *Wounds* as normal, and then multiply by D3.

989-000 VAMPYRE

The blade has an unquenchable thirst for blood, having been forged from bloodstained iron, quenched in blood and polished with dried blood. Its entire purpose is the letting of more blood; nothing else satisfies its craving.

If it wounds a living creature with more than one *Wound* no 'to hit', damage or saving throw die rolls are necessary in subsequent *Hand to Hand Combat Phases*. The blade automatically inflicts damage on the target in subsequent phases, but cannot be used to attack a new target until the object of its blood drinking is dead.

Against other creatures the blade can strike and damage opponents who are immune to non-magical weapons, but has no other *properties*.

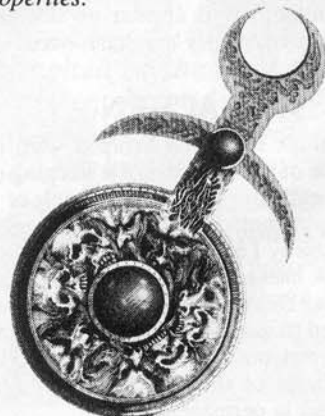





GAMES ★ WE ARE EXCLUSIVE DISTRIBUTORS FOR

ALSO DISTRIBUTORS FOR - THE AVALON HILL GAME COMPANY
VICTORY GAMES INC., NEW YORK, NY. & COLUMBIA GAMES INC.



Now over 275 Games and Extension Modules to choose from!

Available From

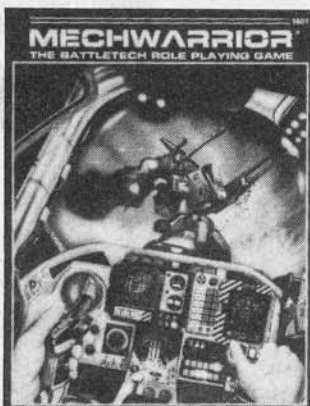

Available From

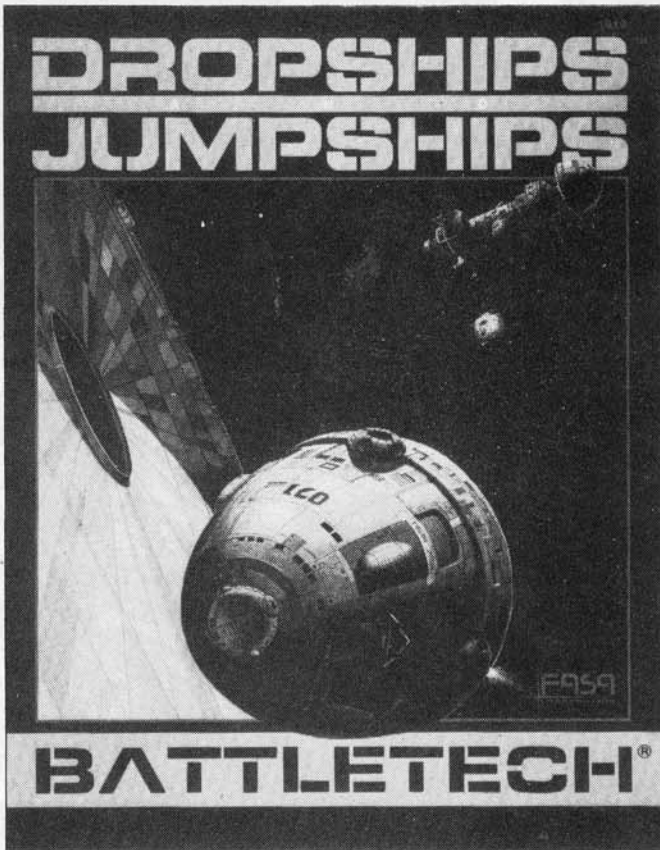

Available From



Available From



FROM GOOD GAMES SHOPS EVERYWHERE

The world of **HARN** is the *ultimate* FRP play-aid; an authentic medieval environment, designed for fantasy gaming. With **HARN**, you can create and plan your own campaigns, quests, and adventures within a complex, realistic background, confident that this world will unfold as it should. ● **HARN** is supported by an outstanding series of expansion modules

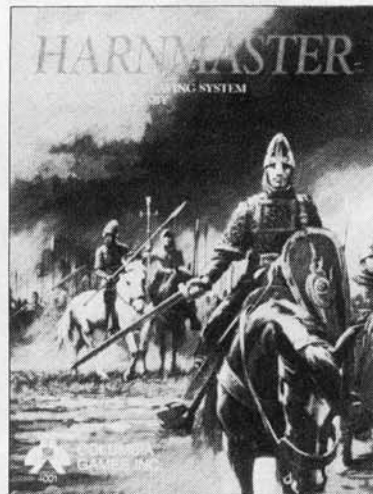
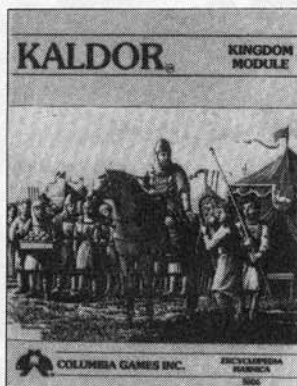
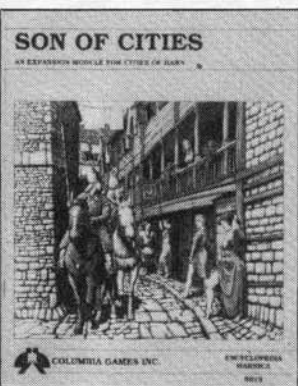

A FANTASY ROLE PLAYING SYSTEM

TRADE & OVERSEAS ENQUIRIES WELCOME

- PHONE FOR DETAILS OF SHOP-SOILED AND TRANSIT DAMAGED GAMES AT REDUCED PRICES
- PLEASE SEND S.A.E. FOR COMPLETE LIST OF GAMES
- IN CASE OF DIFFICULTY IN OBTAINING ANY GAME - WE CAN SUPPLY DIRECT
- UK POST & PACKING CHARGES -
£1.95 FOR ONE GAME · £3.00 FOR 2 GAMES



TMGAMES

CHART HOUSE · STATION ROAD · EAST PRESTON
LITTLEHAMPTON · WEST SUSSEX · BN16 3AG · UK
TELEPHONE: RUSTINGTON (0903) 773170

(ALLOW UP TO 28 DAYS FOR DELIVERY)

WARHAMMER

Armies



They're here. The Warhammer Armies are ready to go to war.

This hardback book is over 150 pages long with lots of full colour plates. It contains complete lists for Chaos, Dark Elf, Wood Elf, High Elf, Dwarf, Empire, Bretonnian, Orc and Goblin, Undead, Slann and Skaven forces. Mercenary and allied contingents of Fimir, Ogres, Half Orcs, Giants, Norse, Nippon and Hobgoblins are also included.

There are new rules for Daemon summoning, new war machines and a revision of the magic point costs for spell casting. The pages are packed with fantastic artwork, colour shield and banner designs, and photographs of sample armies.

Warhammer Armies is your complete guide to tabletop survival. Organise your army now.



CITADEL™
MINIATURES

GAMES™
WORKSHOP

CRUSH · CRUMBLE AND CHOP

Thymbrin rose to his feet with as much dignity as he could muster.

"Not good enough for your precious Engineers' Guild, eh?" he grated. "Well, it's no hair off my chin." He paused to adjust the back of his jerkin, where the sodden cloth was sticking to his skin.

"And I hope your little ritual made you feel suitably important. By stone and steel, it showed the hidebound, frightened shower of fossils you are - yes, *frightened!* You'd sooner shave than have an idea! *Tradition*, you keep on! Where was tradition when we first took mithril and worked it? Where was tradition when the great arches of Zhufbar were built, like nothing that's been seen before or since?"

"*Tradition* - pah!" he spat. "It's stagnation you're building! If you really want to vanish down your own bellows-hole, that's your decision. I'll make my machines without the Engineers' Guild, and cave-ins take the lot of you!"

He woke abruptly as the snake tightened its grip on his throat. Damn that dream, it did it every time.

What a life, he thought as he prised it off, *forever being throttled by your own beard*. He reached under his bunk, snatched up one of the small, skittering things that lived there, and fed it to the snake that sprouted from his chin. It seemed to calm it down.

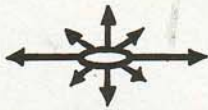

"Well," he said to himself, "I might as well have breakfast too." From a cluster of pots and dishes he collected two handfuls of things better left undescribed, and sat down to eat.

He was about halfway through his meal when someone entered - if the term *someone* can be applied to the huge, dog-faced, black-armoured figure that towered over him.

"Come," it snarled. "It is time for the bloodletting." The Dwarf nodded, and left his meal.

The Champion of Chaos followed him as he made his preparations. First, he went into a workshop, where a dozen or so Dwarfs were working feverishly. All bore the mark of Chaos in some manner.



"Time to go, boys," he called. "Take everything that's finished and everything you can finish on the march." He crossed the workroom to a line of machines which stood ready.

"Simple but effective," he said to the Chaos Warrior. "As you can see, we have two types completed: the Whirlwind, with its rotating blades and flails, and the Tenderiser, with a bank of trip-hammers and heavy maces. Simply get them going fast, and they'll carve you several nice, big, ragged holes in enemy ranks. I'm working on a number of other ideas, of course, but these are what I have ready at the moment."

The Champion of Chaos walked round the two machines, examining the spikes, blades, flails and hammers.

"Great bloodletting," he murmured to himself, reverently touching the skull-rune of Khorne on his breastplate. "Much blood for the Blood God."

"Come along," said Thymbrin cheerfully. "Let's meet the crews. I'm rather pleased with them - made them myself, you know. In a manner of speaking." He led the armoured figure through a series of passages into another large chamber, where two or three dozen forms lay sleeping.

Thymbrin took a horn from a hook on the wall and blew a long, echoing blast. The sleepers awoke, and began strapping on armour. As they moved, their forms could be seen; from the waist up they were Chaos Dwarfs, but they had the bodies and four trottered legs of boars.

"Boar Centaurs," Thymbrin explained. "One per machine. Fast, strong and full of fight - ideal for the job. Just a case of finding the right combinations of mutations and sticking with them."

"We should be ready to march within the hour. Can I offer you some refreshment while we wait? I'm sure we can rustle up some blood from somewhere."



The defending army was formed up and waiting. Elves, Dwarfs and Humans all knew that they must win this day or let Chaos break through into the Forest of Shadows and the Middle Mountains. The Ogre mercenaries were no less determined; their plates had been filled, and their fighting reputation was at stake.

Over the crest of the rise, the forces of Chaos came into view, rank by rank. There were black-armoured riders on warped, variously-legged mounts; towering champions whose massive swords and axes keened with an unholy hunger; Beastmen of all shapes, sizes and colours. And around them, like a roiling sea, seethed a press of other *things* - the Spawn of Chaos.

But all eyes were on the machines which rolled before the Chaos pack. They advanced in a single rank, the width of the Chaos army, with their spiked, two-wheeled frames, their whirling blades and their thrashing hammers.

The Elven archers and Dwarven crossbows loosed two volleys before falling back to their pre-arranged positions. The missiles had little effect, the bulk of them thudding harmlessly into the grotesque carved panels which shielded each machine.

The machines began to gather speed. As they approached, their crews could be seen - centauroid creatures, an unnatural blend of Dwarf and boar. They ran almost as fast as a charging horse, handling the machines as easily as a gardener uses a wheelbarrow.

The machines ploughed sickeningly into the Ogre mercenaries that held the centre. Blades and flails whirled, hammers and maces thrashed. Flesh and sinew shredded, bone and iron shattered. For all their strength and courage, the Ogres were decimated in a matter of seconds.

The centre was now dangerously weak - with the Ogres effectively destroyed, the full force of the enemy would now fall on the Human contingent, and Chaos could break through the centre before the flanks could move to reinforce it. The advantage now lay with Chaos.



WHIRLWIND

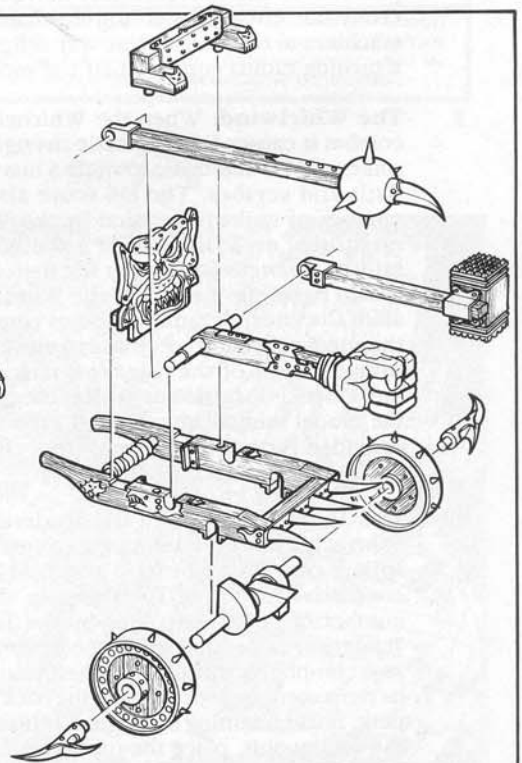
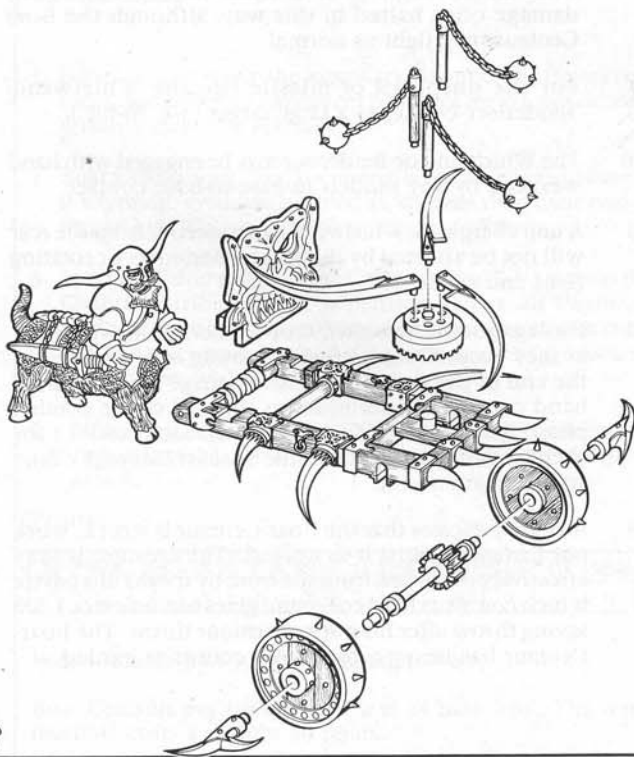

TENDERISER

CHAOS DWARF WAR MACHINES

When it comes to inventing machineries of war, the Chaos Dwarfs are almost as capable as members of the Dwarven Engineers' Guild. Perhaps there is something about their inventive Dwarven nature which responds vigorously to the warping stimulus of Chaos.

The Whirlwind is a two-wheeled push-cart with spikes fixed to the front and scythes protruding from the wheels. Three rotating flails and three rotating scythes are mounted on the front, and are driven by means of cogs and gears linked to the axle. The flails and scythes therefore only rotate while the cart is being pushed. The Whirlwind is principally a device for breaking up and smashing through solid formations of troops. Should the device succeed, it may proceed to engage other targets beyond. Several of these devices may form up in a unit to create a combined attack.

The Tenderiser is a variant of the Whirlwind. Its axle is linked by gears to three enormous concussive implements. As the device is pushed forward these implements batter and crush foes in its path. It operates in a similar way to the Whirlwind except that the nature of the damage inflicted is different.

Chaos Dwarf war machines can be incorporated into any Chaos army as indicated in the box opposite.



SPECIAL RULES

- 1 The machine is pushed into combat by a Dwarf Boar-Centaur. The Boar-Centaur may push the device with a movement allowance of 7" and a normal charge distance of 14".
- 2 The machines suffer the same movement and terrain penalties as chariots. A reserve move is not allowed. A crude but effective steering mechanism enables the machines to turn in the same way as light chariots, with a turning radius equal to half the model's *move*.
- 3 **The Whirlwind:** When the Whirlwind charges into combat it causes D4 automatic *strength* 4 hits with its spikes and D6 automatic *strength* 5 hits with the rotating flails and scythes. The D6 score also indicates the number of ranks penetrated by the Whirlwind. This means that on a D6 score of 4 the Whirlwind would inflict 4 *strength* 6 hits with the flails and scythes and would penetrate 4 ranks. If the Whirlwind penetrates all of the enemy's ranks, it passes completely through the enemy unit, and continues its movement measuring from the back of the rear most rank. If its remaining movement is insufficient to clear the enemy unit, place the model immediately behind - the model's move is extended further than normal, but this is easier than having models overlapping.
- 4 **The Tenderiser:** When the Tenderiser charges into contact it causes D4 automatic *strength* 4 hits with its spikes and D6 automatic *strength* 6 hits with its concussive hammers. The D6 score also indicates the number of ranks penetrated by the Tenderiser. If the Tenderiser penetrates all of the enemy's ranks, it will pass completely through the enemy unit, and continue its movement measuring from the back of the rear most rank. If its remaining movement is insufficient to clear the enemy unit, place the model immediately behind - the model's move is extended further than normal, but this is easier than having models overlapping.
- 5 All Whirlwind and Tenderiser attacks are worked out before normal attacks irrespective of relative initiatives.
- 6 If a Whirlwind or Tenderiser is charged it may still attack, but causes only 1 automatic spike hit, and D3 flail/hammer hits. In this situation the weapon has been caught at a disadvantage and has consequently not gained sufficient momentum to fully activate its mechanism.
- 7 If a Whirlwind or Tenderiser penetrates right through a unit, the unit must take an immediate *rout* test, regardless of how many casualties have been sustained.
- 8 If the Whirlwind or Tenderiser fails to penetrate through a unit, it is brought to a standstill. It cannot cause any damage once halted in this way, although the Boar Centaur may fight as normal.
- 9 For the purposes of missile fire the Whirlwind/Tenderiser counts as a large target (+1 'to hit').
- 10 The Whirlwind or Tenderiser may be engaged with hand weapons by any models in base-to-base contact.
- 11 A unit charging a Whirlwind or Tenderiser from the rear will not be affected by the spikes, hammers or rotating flails and scythes.
- 12 Hits against the Whirlwind or Tenderiser are recorded as they occur. Damage from shooting is determined at the end of the shooting phase. Damage from hand-to-hand combat is determined at the end of the combat phase. To determine damage, roll 2D6 and add +1 for each hit sustained. Consult the *Special Damage Chart* and note any result.
- 13 If chart indicates that the Boar-Centaur is struck, work out damage against it as normal. The creature is very effectively protected from the front by means of a pavise which counts as hard cover and gives him an extra 4,5,6 saving throw after his normal armour throw. The Boar-Centaur has heavy armour and counts as barded.

SPECIAL DAMAGE RESULTS

- 3-7 No effect
- 8-9 The Boar-Centaur is struck, taking 1 hit at the *strength* of its opponent or missile weapon. If enemy models have differing *strength* values, randomly determine which has hit from amongst those in contact with the machine.
- 10 The Boar-Centaur's pavise is struck off, and the Boar Centaur no longer benefits from the extra 4, 5, 6 saving throw after its normal armour saving throw. If struck by a missile weapon with a strength of less than 5, the shot sticks in the pavise and has no effect.
- 11 The machine's steering is seriously damaged. On the D6 roll of 1-3 the machine cannot turn right, or 4-6 left, for the rest of the game.
- 12 The machine suffers damage to its wheels or axle, rendering it particularly unstable. The machine may move at up to half rate without danger. If moving faster than half rate, a D6 is rolled: 1-2 nothing happens; 3-4 the machine moves forward D6" only; 5-6 the axle snaps and the machine comes to an immediate halt. The Boar Centaur may abandon its machine and fight individually.
- 13 The mechanism is damaged and the moving parts are jammed. The machine's whirling blades or hammers are rendered inactive for the rest of the game.
- 14 One of the wheels comes off and the device immediately grinds to a halt causing no further damage. The Boar Centaur may abandon its machine and fight individually.
- 15+ The machine is overturned, wrecking it and causing D3 *strength* 5 hits on the Boar Centaur.

Chaos Dwarf Boar Centaur

Specially bred by the Chaos Dwarf artificer Thymbrin Snakebeard to crew his war machines, the Boar Centaur is an almost perfect blend of compact strength, power and ferocity. Their stamina is almost inexhaustible, and they are capable of carrying or pushing great loads which would require several members of another race. They seem to be dedicated purely to crewing Snakebeard's machines.

Physique. As their name suggests, Boar Centaurs consist of the body of a boar, with the torso and upper body of a Chaos Dwarf growing from the neck. The coarse fur on the boar body can vary widely, from the natural browns, greys and mottled patterns of a normal boar to the brighter, more unnatural shades which emphasise their Chaotic origins. The upper body is generally pale, often with a bluish or greenish tinge, but may be more brightly coloured or even patterned.

Alignment. Chaotic.

Base Size. 25 x 50mm.

Special Rules

1. Boar Centaurs retain the legendary vigour of the Dwarven races, and suffer no movement penalties for armour or for pushing their war machine.
2. Boar Centaurs are bred for strength and stamina, and are, if anything, even less talented as Wizards than their two-legged kin. There are no Boar Centaur wizards.
3. In competition games, Boar Centaurs have D4-3 personal Chaotic Attributes. In competition games, all Chaotic Attributes must be generated under the supervision of the GM. In non-competition games, attributes may be generated if the player wishes.
4. When the Chaos Dwarf Boar Centaur is engaged in hand-to-hand combat, it has one weapon attack and one *stomp* attack.

Profile

M	WS	BS	S	T	W	I	A	Ld	Int	Cl	WP
7	4	3	3	4	2	2	2	9	7	9	9

Points (Basic): 34 + 50 (War Machine) = 84.

Boar Centaurs pay for equipment at x4 basic cost. The war machine costs a straight 50 points.

0-3 CHAOS DWARF WAR MACHINES

	M	WS	BS	S	T	W	I	A	Ld	Int	Cl	WP
BOAR CENTAUR	7	4	3	3	4	2	2	2	9	7	9	9

MODELS PER UNIT: 1-4
POINTS PER MODEL: 120

WEAPONS:
 DOUBLE-HANDED
 WEAPON

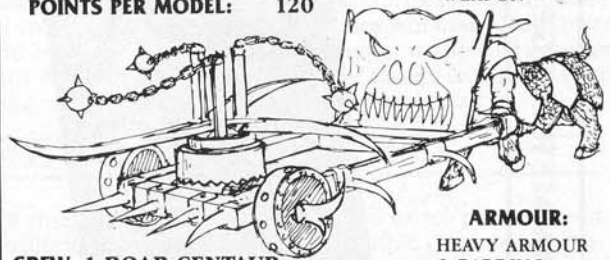

ARMOUR:
 HEAVY ARMOUR
 & BARDING

CREW: 1 BOAR-CENTAUR

These awesome war machines were devised by the notorious Chaos Dwarf inventor who also bred the Dwarf Boar-Centaurs to crew them. There are two types, the 'Whirlwind' with rotating flails and scythes, and the 'Tenderiser' armed with three enormous concussive implements.

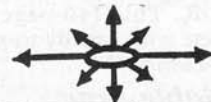

MAIL ORDER

BLOOD BOWL

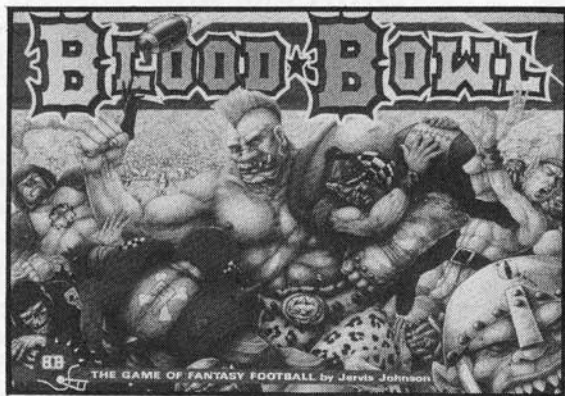

Bigger, better, **new!** This is BLOOD BOWL - where war is a whole new ball game. The pack includes: two highly detailed hand-sculpted plastic miniature teams, basic and advanced rules, Blood Bowl Handbook and the amazing Astrogranite pitch!

Available Now £19.99

DARK FUTURE



Can you survive in the world of DARK FUTURE? - where hardened Outlaws fight ruthless Sanctioned Operatives along the desolate highways of a drought-ridden America. The Game of Highway Warriors is packed with the very best of GW art and miniatures.

Summer 1988 Release £19.99

WARHAMMER SIEGE



WARHAMMER SIEGE covers every aspect of siege warfare, from fortress design to enemy assault in both the Old World of WFB, and the stellar realms of WH40K. This 140-page hardback book comes complete with a ready-to-play siege, *The Defence of Caraz-Lumbar*.

Available Now £12.99

THE MIGHTY FORTRESS

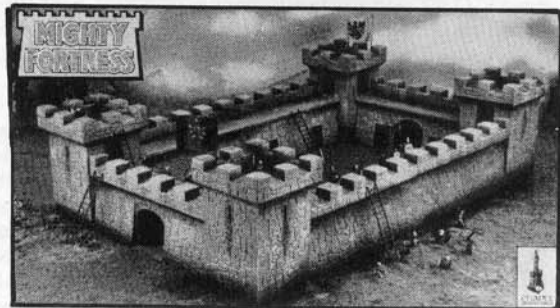

The biggest model release yet from the Citadel design team. This full-sized castle kit is made from high-density, expanded polystyrene, and includes 4 walls, 2 gateways, 4 towers and numerous hard plastic accessories from doors to flagpoles.

Available Now £19.99

WARHAMMER ARMIES

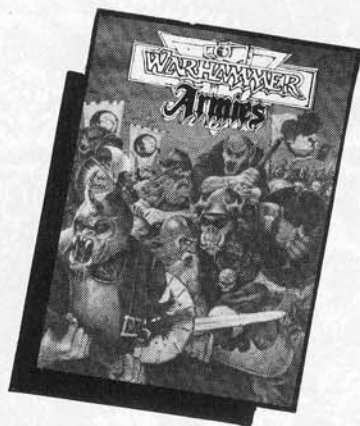

The definitive guide to the fighting forces of WFB. This hardback volume contains magic rules, bestiary, banner illustrations, and the army lists themselves - including details on allies and mercenaries - plus 20 pages of full colour artwork.

Summer 1988 Release £14.99

POWER BEHIND THE THRONE



The fourth adventure in the ENEMY WITHIN Campaign involves characters in a desperate race against time to combat intrigue and deception at the highest levels of Imperial society. Fully compatible with WARHAMMER CITY: A Complete Guide to Middenheim.

Available Now £9.99

Placing your order now will ensure you receive new releases as soon as they are available.

RHINO BOXED SET



Three complete model Rhino Kits wait for your Tech Priests to build them and your Imperial Commanders to take them into battle. Whether you command Imperial Guard or Marine Units, a detachment of Rhinos provides the extra killing power you need.

Summer 1988 Release £9.99

DUNGEONQUEST CATACOMBS

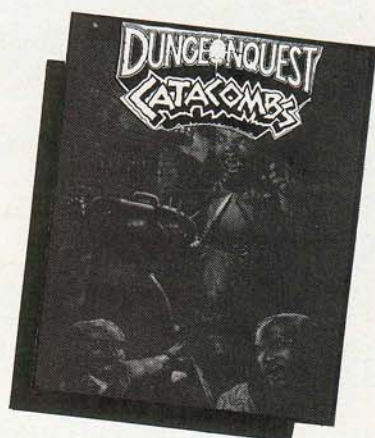

Return once again to the awesome Dragonfire Castle of the DUNGEONQUEST boardgame. New cards and monsters allow exploration of the lower levels in search of the Dragon's Treasure Chamber. But be warned, the perils that lurk are not for the faint of heart!

Summer 1988 Release £6.99

- Warhammer Fantasy Battle (3rd Edition).....£14.99
- Warhammer Fantasy Roleplay.....£14.99
- Warhammer 40,000 Rogue Trader.....£14.99
- Curse of the Mummy's Tomb.....£14.99
- Heroes for Dungeonquest.....£9.99
- Expert Paint Set.....£5.99

Golden Demon Tickets

Tickets are available now for the Grand Final of the 1988 Golden Demon Awards, to be held in the Victoria Leisure Centre, Nottingham July 30th. Tickets are £1.50 on the door, but you can get yours now from Games Workshop Mail Order (and any Games Workshop retail shops) at a special advance price of £1.00 each! The number of tickets is limited, so to avoid missing out on the day, order yours now!

ORDERING CITADEL MINIATURES

You can order any of the figures in this month's WHITE DWARF simply and easily, either by mail or telephone Credit Card order. Our fast, computerised service is very reliable, and the majority of orders are dispatched within one working day.

When ordering figures, please state the following information:

- *range code and name (as shown below), *the figure's photograph number (refer to advert),
- *the price, *and the magazine issue you are ordering from.

For instance, to order the Iron Claw Goblins you might ask for: "IC602 Iron Claw Goblins, numbers 1, 2, 3, 4 and 5, at £2.50 for five, shown in White Dwarf 103."

FIGURE CODE	RANGE/NAME	SHOWN ON PAGE	PRICE
RT107	RHINO CREW	2	£2.50 for 2 complete Marine outriders, 1 Marine (upper torso only) and 1 hatch converter
IC602	IRON CLAW GOBLINS	7	£2.50 for 5
CH3	CHAOS WAR MACHINES	10	£3.50 each including crewmen
ORC1	ORC WARRIORS WITH CROSSBOW	10	£2.50 for 5
BB107	OGRE	10	£2.50 for 2 (same figure)
BB107	TROLL	10	£2.50 for 2 (same figure)
RT601	PIRATES	15	£2.50 for 5
RT305	SQUAT MOTORCYCLES	18	£2.50 each
RT404	ELDAR FIELD ARTILLERY	18	£2.50 for 2 weapons and 2 crewmen
RTB04	RHINO	BC	£9.99 for 3 complete kits

HOW TO MAIL ORDER

Make cheques payable to Games Workshop Ltd. Include cost of Postage and Packing:
Please Note: Minimum Order £5.00

UK, Eire & BFPO: Add £1.00 for Orders under £15.00
Orders over £15.00 are Post Free

USA: Credit Card Orders only, sent Airmail at cost

OVERSEAS (ex.USA): Add 33% for Carriage

OVERSEAS (ex.USA) AIRMAIL: Add 40% for Carriage

HOW TO TELEPHONE ORDER

BARCLAYCARD/VISA & ACCESS

Simply and Quickly Telephone Your Orders Direct to us on our Hotlines

(0773) 713213 or (0773) 760462

Monday to Friday Between 8.30am and 5.00pm

GAMES WORKSHOP, Chewton Street, Hilltop, Eastwood, NOTTINGHAM, NG16 3HY



MAIL ORDER



HEAVY METAL

RANGE OF RHINOS

This month we're going to concentrate on the latest phase in Citadel's development of plastic gaming models and miniatures. As you have seen elsewhere in this issue, we have dealt with the *Rhino's* place in Imperial History, examined its battlefield capabilities, and inspected a variety of liveries.

And the AFV's famed versatility has inspired a number of staffers to experiment with their own *Rhino* variations. The results are extremely interesting. *John Blanche* puts them into neutral and gives them a look over.



On Tim Pollard's conversion (which involved a deep bits-box delve), the simple but effective paint job is highlighted by using some of the decals from the spare bits collection. Note the turret mounted multi-melta.



An early Rhino kit experiment by Sid. Note the headlamp cavities. They were painted yellow and filled with PVA glue. The glue becomes transparent when dry, hence the realistic headlamp effect.



Blood Drinker marines take a well-earned rest before driving their two Rhinos into another battle.

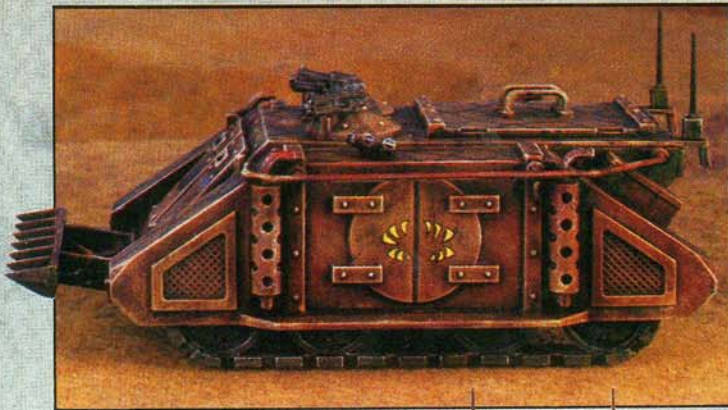

Brown camouflage scheme by Darren Matthews. The damage to the front of the vehicle was made with a scalpel and liquid polystyrene cement.



Codex approved camouflage scheme (see camouflage guide on p64-65). Note the graffiti and flags adorning the machines.

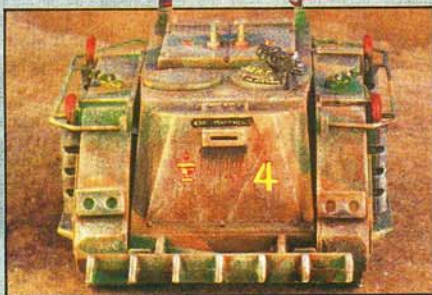
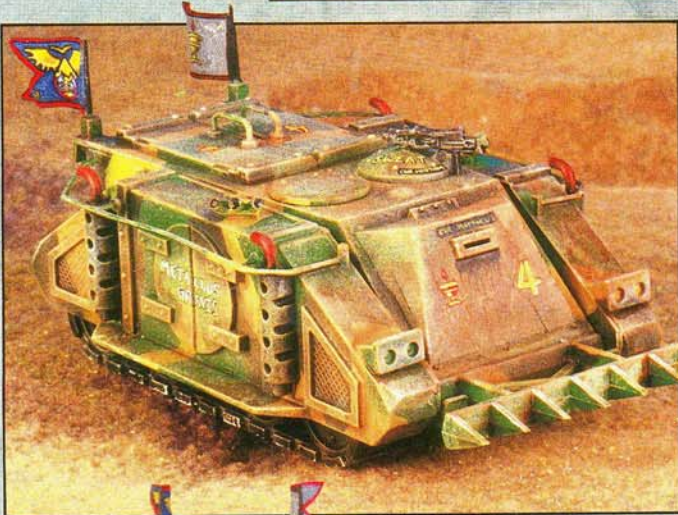

Another Codex approved scheme, more graffiti and more flags.



Codex approved grey. This colour forms the basis for Rhino livery in the Legiones Astartes. Imperial Guard Rhinos use olive green as their base colour. Model painted by Darren Matthews.



Two rear views by Darren Matthews.



This conversion by Workshopper Tony Cottrell uses chains, mesh and wire from the spares box to give the Rhino an extra-heavy feel.

The *Rhino* armoured personnel carrier is Games Workshop's first polystyrene construction kit, other than figures, and as such follows the same construction and painting principles that we discussed when we talked about plastic marines (WD 94). The kit is very easy to construct and a number of variations are made possible by virtue of the component design. It's also very versatile in terms of conversion possibilities, particularly when using parts from other commercially produced kits. This article is just a taster in that respect. Let's see what you can do with a few bits of plastic and some imagination.

These examples were made when the first mouldings arrived at the Studio, but I can well imagine the scores of support weapons, mine sweepers, bridge layers... as well as a myriad of colours in the months to come.

For those of you not familiar with kit building and painting, don't be put off if it appears to be intimidating in any way. The kit's simplicity will encourage your efforts. Following normal procedure, clean each part with a modelling knife and assemble with polystyrene cement. You can paint the *Rhino* very quickly and relatively easily, in fact much more easily than a figure. By far the most effective method to employ is a drybrushing technique which will give a weathered, dusty effect. As usual for this technique, having first undercoated and base coloured your vehicle (spray paints are ideal for this purpose), a lighter shade of the base colours can be applied. A cheap or old brush is ideal for this purpose, with the bulk of the pigment being removed from the brush with an old rag before application. The brush is lightly drawn across the surface with swift wrist movements. What pigment is left on the brush adheres to the raised parts of the model, effectively highlighting it. Pale greys and beiges produce excellent weathering effects. Guns, ariels, grills etc can be painted black, metallic or to choice, as can rust patches and battle damage.

The most difficult aspect of the paint job will be the insignia and banners. Now I'm sure many of you will adorn your vehicles with the utmost of care and skill, but for those of you with less time or ability, transfer sheets are included in the box. Of course transfers from other commercially available kits can be utilised as can Citadel's own Arcane Armorial decal set.

The Codex grey *Rhino* represents the normal colour of the Marine *Rhino*. Darren's version was painted with Skull Grey and Black mix, the whole model was then given a wash of Chestnut ink, which shows through the lighter grey drybrushing as rust. Further rust was then applied around rivets with Chestnut ink. The exhaust, guns and grenade launchers were painted with Chaos Black and subtly drybrushed with Mithril Silver. Darren then carefully painted the insignia and banners with a fine detail brush.

The camouflaged versions were then painted using Woodland Green as a base colour with the camo stripes being added using a brown ink and Bestial Brown mix and Orc Brown and Chestnut ink mix. The model was then drybrushed with a lighter tone of the beige (and white). This colour scheme follows conventional US winter colour schemes used in Europe. Obviously you will have to consider the type of planet that your *Rhino* will operate on, and vary your camouflage schemes accordingly. For instance, Darren has adopted a brown and black colour scheme for his own *Rhino*. Note the fang insignia and virtually white drybrushing giving the vehicle a very dusty look.

Sid's pre-production model was painted very quickly with an air brush which is ideal for subtle camouflage effects. Even if you don't own such equipment, spray cans are ideal for providing base colours on which to add further detail. A nice touch on this model is the way Sid has filled the headlight depressions with blobs of school glue which turns transparent when dry.

Two very interesting *Rhinos* built and painted by Games Workshop staffers Tim Pollard and Tony Cottrell, involved deep delves into their plastic kit bits boxes. They added such things as chains, ariels, tools, packs, radar dishes and a variety of tools. The results are most effective, and the paint jobs remarkably similar. A base colour of black was dry brushed with grey metallic and other details were then added. Kit decals provide the final touch.

Of course there are no limits to converting your *Rhino*. You only have to look through books on military vehicles or at kits at your local model shop for inspiration. The photos here show 3 variants by Bob Naismith, figure designer, artist and supremo of our plastics division. They were made using bits of *Rhino*, bits from the bits box, figure bases, plastic shields, Plasticard, Milliput, rivets, aluminium tubing, various metal weapons, and a fair amount of haggis and Royal Salute. Next month we will bring you more ideas and a template scheme so you can convert your own *Rhinos* into Bob's designs. You fanatical figure painters out there need not feel hard done to though, for in the same ish I'll be bringing you a very special *Realm of Chaos* 'Eavy Metal - weird and wonderful and everything!



John Blanche

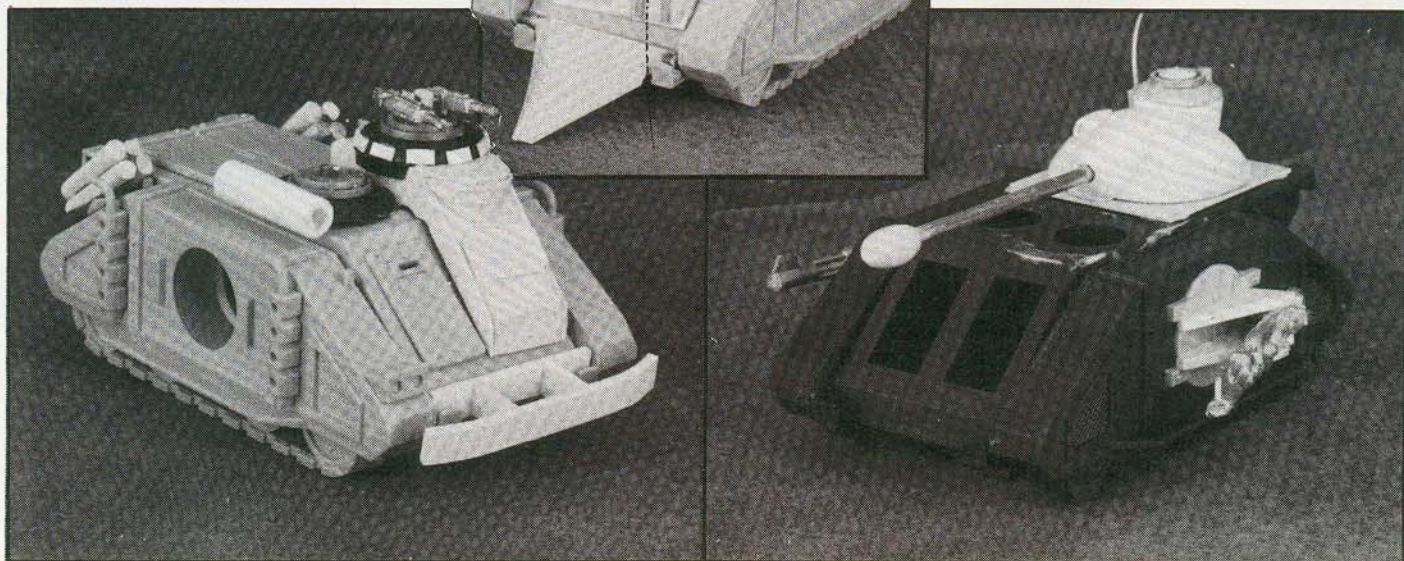

WHITE DWARF

PSST! Do you want some free games?

OK, so **White Dwarf** is the leading games magazine in the UK, but we aren't proud. Our membership may be increasing month by month, but we don't let that go to our head. We want you to subscribe, and we're offering *free* hardback books to make sure you do.

Choose from:

- Stormbringer**
- Paranoia (2nd Edition)**
- Runequest (Basic)**
- Runequest (Advanced)**
- Runequest (Monsters)**
- Land of Ninja**

To claim your free copy, simply select one from the list above, and take out a subscription by sending us a completed form before 1st August 1988 (USA 1st September 1988). Please mark your envelope 'Subscriptions'.

Credit Card Holders: If you prefer, you can take out a subscription by ringing our Hotlines on (0773) 713213 or 760462. We accept Barclaycard/Visa and Access.

In USA please telephone 301-727-0252

Subscription Rates

	12 issues	24 issues
UK, BFPO & Eire only	£18	£36
Europe	£36	£72
USA	\$32	\$64
Other Overseas (Surface Mail)	£36	£72
Other Overseas (Air Mail)	£54	£108

Dear Games Workshop, I would like a subscription to **White Dwarf**, I claim

.....
as my free gift, but in case stocks have run out I would be happy with

.....
★ ★ ★ ★ ★

Name

Address

.....

.....

..... Postcode

One or two year subscription (please circle): 1 2

Amount enclosed

Are you re-subscribing?
Yes No

Please start with issue

Payment: Please make all cheques, postal and money orders payable to Games Workshop Ltd, and in Pounds Sterling only. US customers please make cheques payable to Games Workshop US, and payable in US Dollars.

Credit Card Payment: Please debit my Access/Visa card (Delete as appropriate).

Card Number:
[] []

Expiry Date

Signature



UK SUBSCRIBERS
Games Workshop
Chewton Street,
Hilltop,
Eastwood,
Nottingham,
NG16 3HY UK

US SUBSCRIBERS
Games Workshop US
1220 Key Highway,
Baltimore,
Maryland,
21230 USA

ILLUMINATIONS

CARL CRITCHLOW

Carl's art has been around for some time now in the form of one of WD's longest running and most popular features, *Thrud*. His unique, chunky comic book technique provides the perfect vehicle for the biffesque barbarian.

Carl also loves motorbikes. It seemed ideal, therefore, to rope him into working on our new *Dark Future* project (some of his work appeared in last month's special introduction to the *DF* mythos). Here's some more of his work plus a page from a biker strip he drew for *Back Street Heroes*.

Don't say we never treat you.

John Blanche



Carl Critchlow

Age: 24
Zodiac: Libra
Education: Liverpool Poly dropout
Artistic Mentor: Brian Talbot
Influences: Berni Wrightson, Frank Frazetta
Ambition: to be able to oil paint
Music: Steve Ray Vaughn
Films: *Mad Max*, *Blues Brothers*, *Akira*, *Kurosawa*
Pastime: Messing about with motorbikes



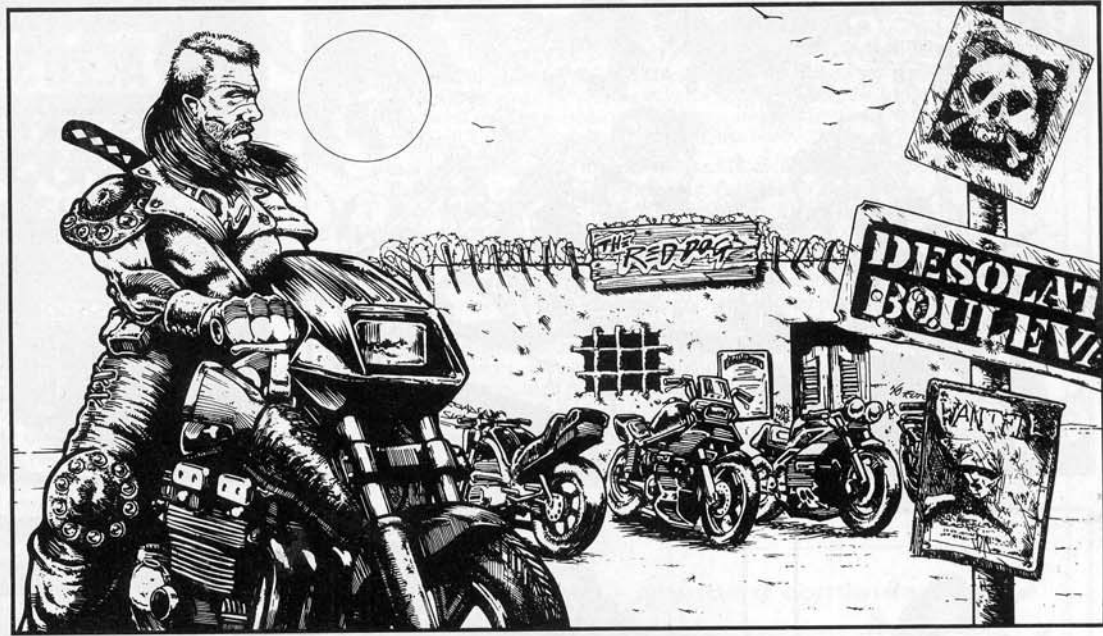

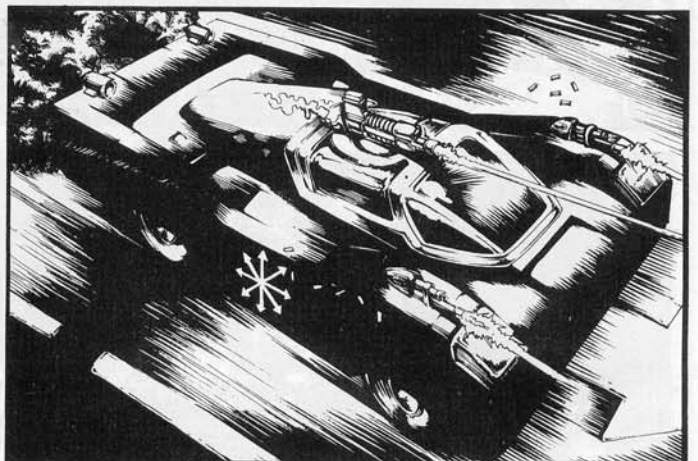
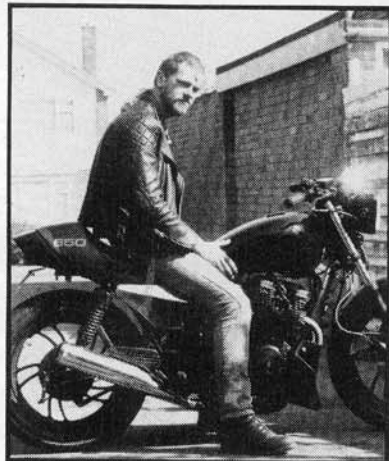

RAMPAGING RHINOS

During the Dark Age of Technology man's conquest of the stars relied on the impetus of the Standard Template Construct system. These complex analytical and processing systems enabled the colonists to fabricate their basic needs from locally available materials. Although none of these systems are known to function today, many designs derived from them survive as a tribute to humanity's pioneering past. Cultural changes, fashion and subsequent development have modified the shapes and styles of STC blueprints, but basic designs are still recognisable in many utilitarian devices of the forty-first millennium. On some worlds items are religiously copied and various social constraints exist to prevent change.

One legacy of the STC is the ubiquitous armoured carrier RH1 N0 - Tracked Exploration and Multi-defence - a vehicle designed for action in hostile environments, known as the Rhino. The vehicle is primarily seen in the service of Imperial forces, but Orkish variants are not uncommon. These are salvaged from the wreck of battle, and may be extremely ancient. Some Ork Warlords have developed their own - usually inferior - copies.

The basic design of the Rhino has remained unchanged for over ten thousand years. Its shell is made from almost any material, the fittings can be varied by the designer. Some uniformity of fittings and materials has become traditional amongst the Imperial Guard - the space army of the Imperium. However, examples made from all sorts of materials, can be found on remote planets. The profile given is for an Imperial Guard or Marine vehicle built from conventional materials.

The Rhino has seen action in a wide range of operational theatres. This has led to great diversity in camouflage schemes employed, even though Imperial regulations - as laid down in the *Codex Imperialis* - are strictly followed by the Tech Priests of the Adeptus Mechanicus at the time of construction.

Once a vehicle is accepted by an Imperial force, colour scheme reflects its operational role, and camouflage patterns take account of climate, terrain and vegetation. Occasionally, a Marine Chapter will simply use its own associated colours. In special cases, particularly bright and garish schemes are used to wage psychological warfare on the superstitious natives of medieval or feral worlds. Ork schemes are predominantly red, following the well-known adage of Orkish 'Know-wot', 'Red unz go fasta!'

It is a testament to the foresight of the STC architects that the Rhino design has proved such a long lasting one. Part of this longevity is due to the major tenet of the STC system - universality. STCs can be made out of just about anything, and they can be made extremely quickly.

For example, during the Badab wars, the rebel Tiger Claws chapter suffered early losses of equipment when transports were lost to the warp. To offset the ensuing deficiencies, an emergency building program was instituted, producing thousands of Rhino variants. As the Badab constructors were hounded from production facility to production facility by the advancing enemy forces, they were reduced to using locally available materials, including moulded plastics, compressed organic material and eventually even plywood.

Vehicles constructed under these desperate circumstances later took part in the Colon Salient suicide counter-attack, when a squadron of Rhinos broke through to the Fire Angels' lines and detonated a viral missile, causing more casualties in a single day than the Fire Angels had suffered in the war up to that point.

O-10 Rhinos - Standard configuration

Land		TRR	CP	T	D	Sv	Eq	W
max speed	acc/dec							
16	4	1	12	8	40	4-6	12	10

Equipment: 1" radius Power Field, Power Field Synchroniser, auto-aim, auto-drive, auto-fac, ejector seats, 2 targeters, communicator, sensor package (bio-scanner, energy-scanner, rad-counter), medi-pack.

Weapons: 2 Bolt guns, provision for 8 weapons points.

Points: 289 + 83½ (equipment) + 4 (bolt guns) = 376½

RICK PRIESTLEY

For Inclusion in Army Lists

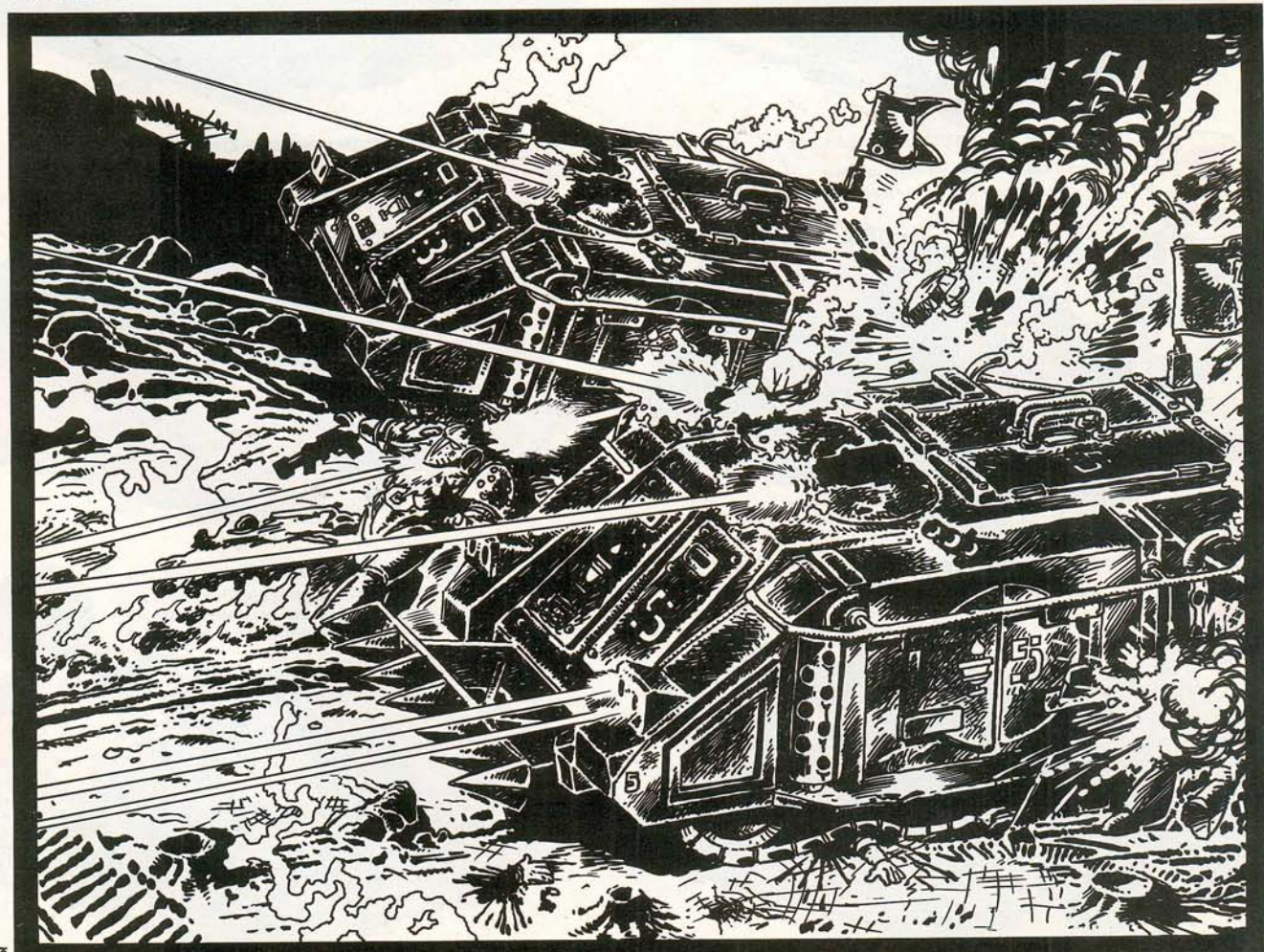

RHINO

ARMoured ASSAULT VEHICLE



LEGIONES ASTARTES:
CODEX GREY (BLOOD DRINKERS)



IMPERIAL GUARD:
CODEX OLIVE-DRAB ('LUCKY SEVENS')



CODEX INCEPT PATTERN: MEDIC

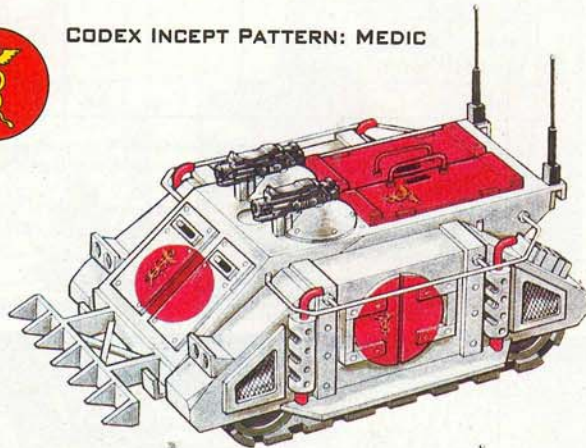

CODEX INCEPT PATTERN: CHAPLAIN

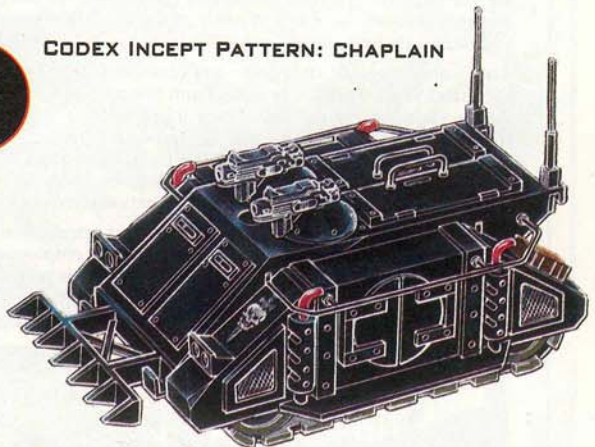

CRIMSON FISTS:
CHAPTER COLOURS (NON-CODEX)

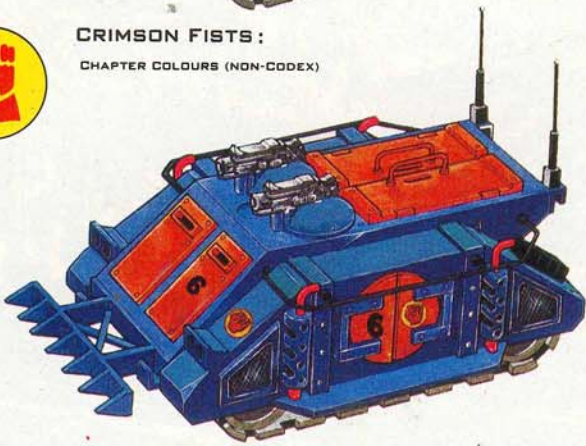

FIELD COMMANDER CRIMSON FISTS:
PERSONAL LIVERY



1 BLOOD DRINKERS
MASSACRE OF DELTA 9

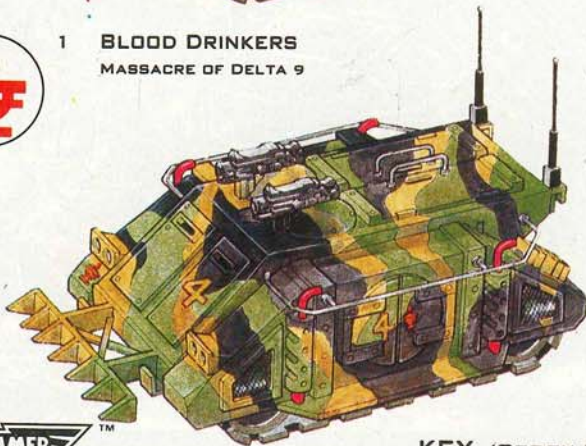

2 DARK ANGELS
THE EGAMMONON REVOLT:
FOURTH QUADRANT REBELLION

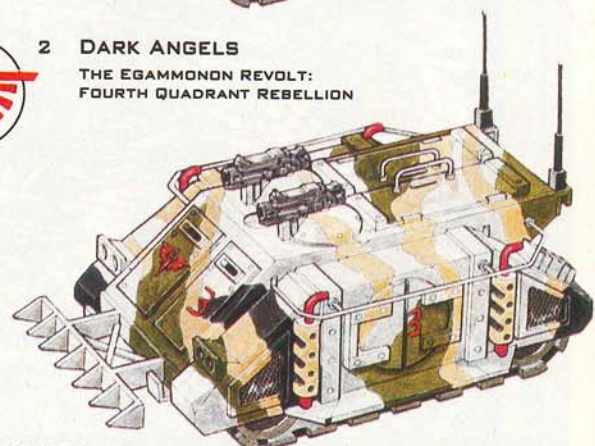

KEY (CODEX PATTERN VARIANTS)

- 1. TEMPERATE: VARIABLE TERRAIN
- 2. SUB-ARCTIC: TUNDRA
- 3. SUB-ARCTIC: MOUNTAINOUS
- 4. ARCTIC: ICECAP





CODEX CHAPTER BANNERS:

CODEX RHINO BANNERS:



BLOOD DRINKER RHINOS

LEGIONES ASTARTES AND IMPERIAL GUARD



3

IMPERIAL GUARD
3RD RGT 'THE WRECKING CREW'
TASK FORCE REAPER:
TRANQUILITY CAMPAIGN

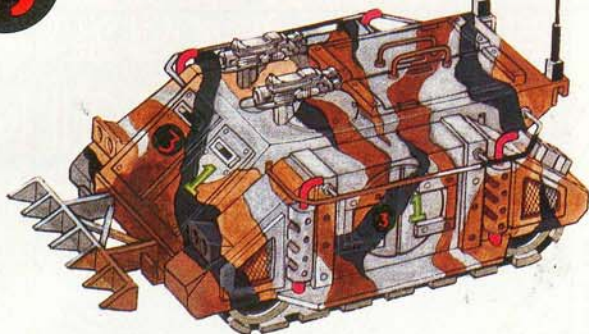

1

IMPERIAL GUARD
1ST RGT 'THE BIG ONE'
SKIRMISH ON BRIDGE-GLACIER RIGEL:
THE BADAB WAR
(NOTE UNPAINTED REPLACEMENT PANEL)

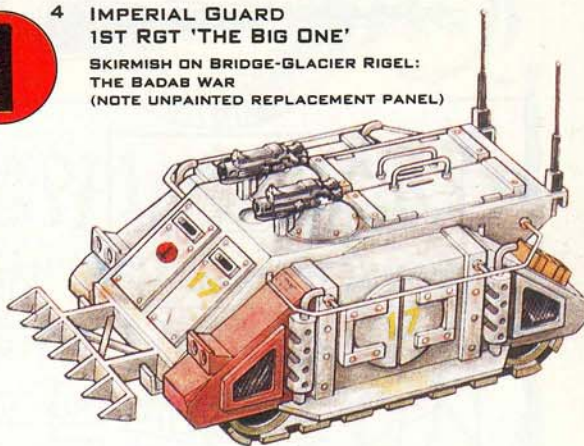

5

ULTRA MARINES
ASSAULT ON IKKYO: LAST TYRANIC WAR



6

WHITE SCARS
'422' PATROL: INCIDENT ON
DEATH-WORLD CANAK



7

IMPERIAL GUARD
8TH RGT 'THE SPIDERS':
RELIEF FORCE - SIEGE OF FORT WRATH

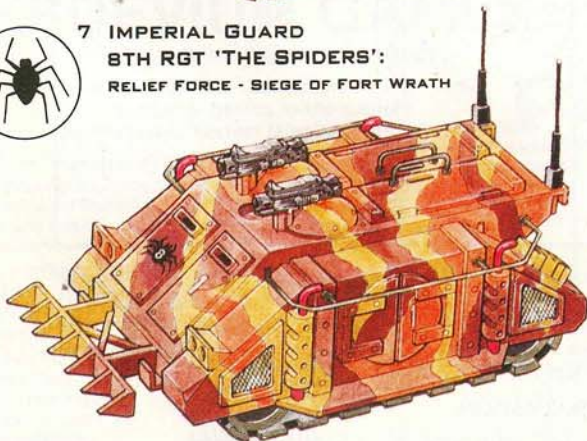

8

FLESH EATERS
SPEARHEAD FORCE:
THE ALVATINE SUPPRESSION

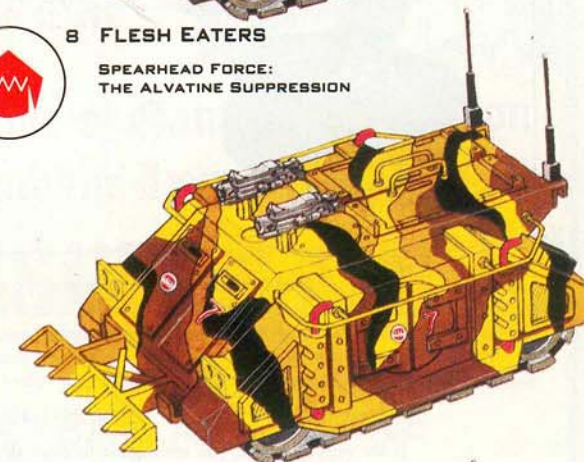

1

IMPERIAL GUARD
1ST RGT 'THE BIG ONE'
BATTLE OF KRUGER RIDGE:
CROW'S WORLD CAMPAIGN

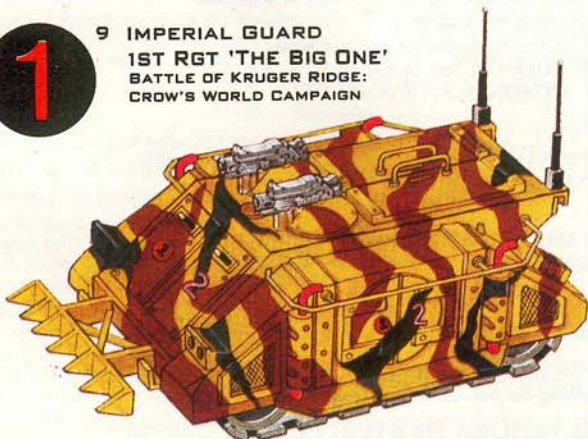

10

IMPERIAL GUARD
'FIGHTING 9TH' RGT
ASSAULT ON TSUNAMI REEF
(NOTE BOLTER DAMAGE
TO LEFT FLANK)

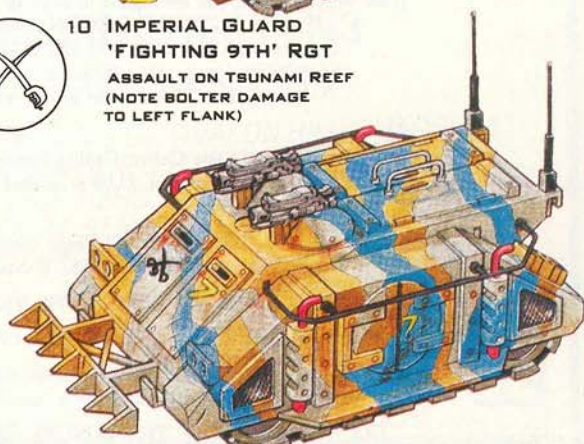

5. SUB-TROPICAL: FORESTED
6. TROPICAL: VELDT

7. DESERT: IRON OXIDE
8. DESERT: SUPHUR OXIDE

9. DESERT: DEATH WORLD
10. SALT PLAIN: AMMONIUM-BASED

GOLDEN DEMON AWARDS

The Second National Figure Painting Championship

1988

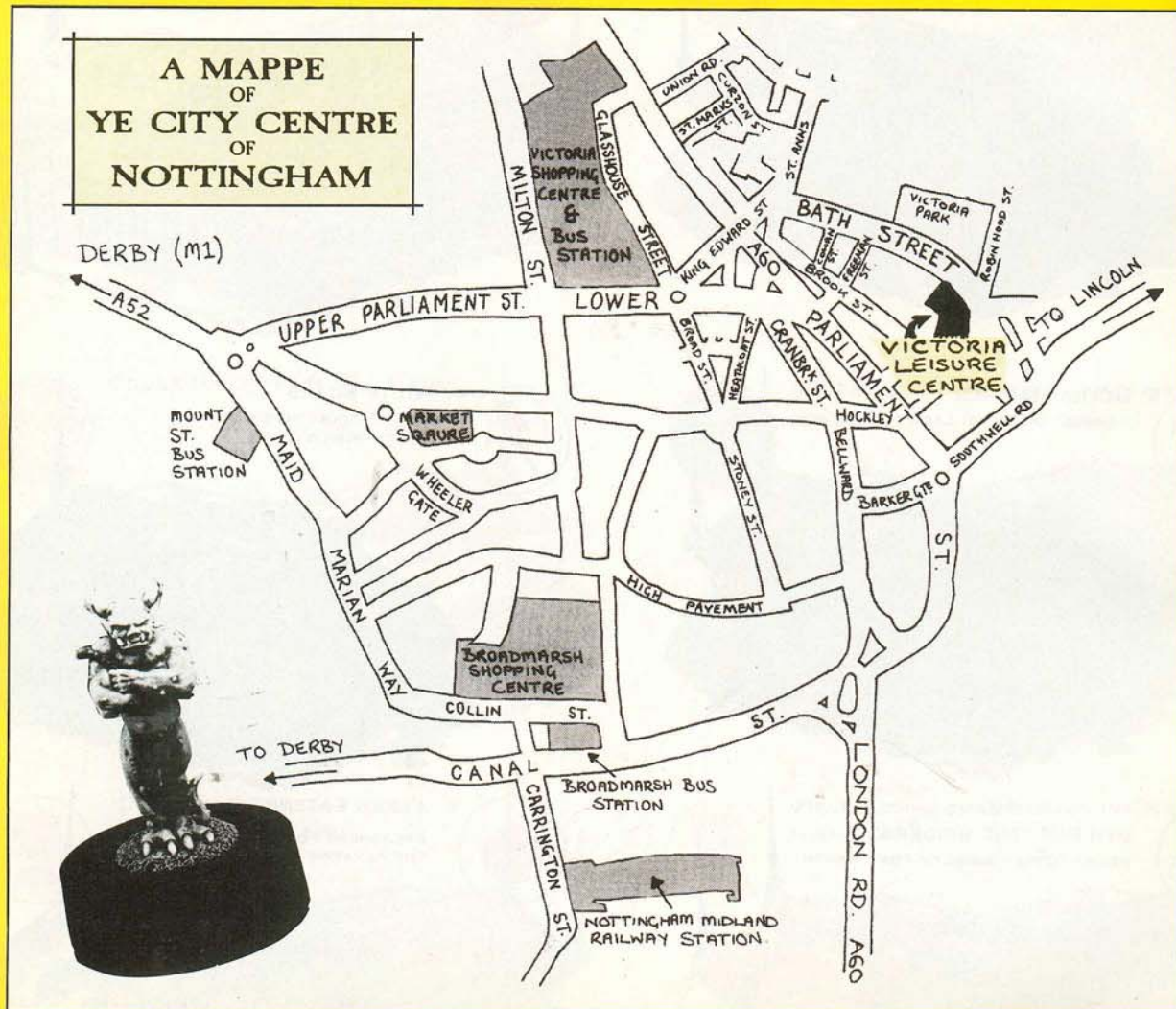

The regional heats of this awesome event have been won, and the contestants retired to lick their wounds. As is the way with competitions, not everyone could win, though the standard of entries was superb throughout. If you did not win, do not be dismayed! THE GOLDEN DEMON AWARDS GRAND FINAL will be a day for everyone! Demonstrations, participations, seminars, competitions, 'Eavy metal live and much much more!! All this plus a huge Games Workshop trade stand featuring a plethora of brand new products... So if you want a great day out, and the chance to see more exquisitely painted miniatures than you ever thought existed you simply cannot afford to miss the GOLDEN DEMON AWARDS GRAND FINAL.

REGIONAL HEAT WINNERS INFORMATION:

- 1) By winning a heat, you are eligible to enter all the categories at the final, and thus may be the winner of a coveted GOLDEN DEMON AWARD and thousands of pounds worth of prizes.
- 2) If you wear your MASTER PAINTER t-shirt on the day, then you are entitled to free admission.
- 3) The best entries will feature in a forthcoming GOLDEN DEMON hard backed book!
- 4) The 'best of show' exhibit will win the GOLDEN DEMON SLAYER sword.

VITAL INFORMATION

- ★ VENUE: The Victoria Leisure Centre, Gedling Street, Sneinton, Nottingham ★ DATE: Saturday 30th July ★ TIME: 10am-5pm
 ★ TICKETS: £1.50 on the door, £1.00 in advance from Games Workshop mail order or from Games Workshop shops.

CATEGORIES:

- 1) Single figure, 2) Single conversion, 3) Monster, 4) Dragon, 5) Mounted Figure
- 6) Vignette: fantasy, 7) Vignette: 40K, 8) Standard bearer, 9) Scratch built vehicle, 10) Best squad of marines

HOW TO GET TO THE VICTORIA LEISURE CENTRE, NOTTINGHAM

- ★ From the North: M1 (junction 26), or the A1, A52 or A6 ★ From the South: M1 (Junction 25 or 26), or the A453, A6 or A50/60

Once you are in the vicinity of Nottingham, follow signs for the City Centre. Then use the map provided to find the centre. There are plenty of nearby car parks. By train or bus, the centre is within walking distance from the stations!

DO NOT CONFUSE THE LEISURE CENTRE WITH THE VICTORIA SHOPPING CENTRE!

Modelcraft

Proprietor: Bob Wighton

WHITE HART MEWS, SOUTHGATE, SLEAFORD
LINCS, NG34 7RY
TEL: (0529) 307360

ARNOLDS GIFT CENTRE

4 HIGH STREET
BRENTWOOD
ESSEX

Stocking a comprehensive range of
exciting Games Workshop Games
and Citadel miniatures.
Why not pay us a call?
We're open Monday-Saturday
9am-6pm

Toytown

LEADING TOY & MODEL SPECIALISTS

105 REGENT STREET,
LEAMINGTON SPA,
WARWICKSHIRE
CV32 4NU

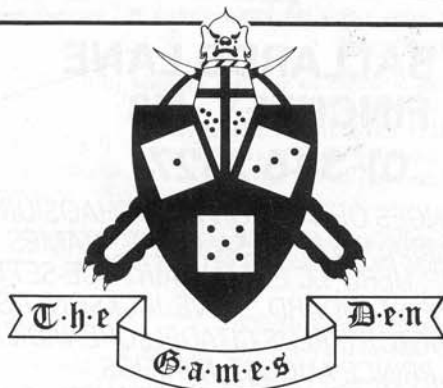

For All Your Roleplay And Wargame Needs

154 High Street, Broadstairs, Kent. Tel: 0843 61658

TORBAY

IS PROUD TO PRESENT ...

! THE FOREMOST RANGE OF RPG'S, CITADEL
MINIATURES AND GAMES WORKSHOP BOARD
GAMES ANYWHERE IN TORBAY.

! WEEKLY DELIVERIES OF ALL THE LATEST IN
GAMING PRODUCTS.

! AN EXPERIENCED GAMES PLAYER CHAINED TO
HIS POST TO ENSURE THAT HELPFUL, CONS-
TRUCTIVE, (USELESS/UNWANTED) ADVICE IS
ALWAYS AVAILABLE.

! AND IF YOU WANT TO BROWSE, (BECOME
HORRIBLY OVERWHELMED BY OUR ENORMOUS
SELECTION/FAINT IN FRONT OF OUR LOVELY
DISPLAYS), WE PROMISE NOT TO EAT YOU.

SO LIKE THE MAN SAID. COME ON DOWN!

TOY TOWN

34 LUCIUS STREET
TORQUAY
DEVON.
Tel. (0803) 22029

★ A NEW SHOP ★

in Leicester City Centre

ANOTHER WORLD at 23 SILVER STREET

(off the High Street, 200 yards from the Clock Tower)

TWO FLOORS WITH OVER 1600 SQ. FT. FOR ALL YOUR
FANTASY, SCI-FI & WAR GAMES PLUS ACCESSORIES.
ALSO STOCKING AMERICAN & BRITISH COMICS,
T-SHIRTS POSTERS, SCIENCE FICTION PAPERBACKS,
BOOKS ON FANTASY, ART, MARTIAL ARTS, ROCK
MUSIC, BODY-BUILDING, COMBAT, OCCULT, FILMS,
T.V., ETC.

Also at FANTASY WORLD, 10 Market Square
Arcade, Hanley, Stoke-on-Trent, Staffs.

DANIELS OF WINDSOR



The Department Store of Windsor
120 Peascod St. Tel: 0753 862106

WARHAMMER™

Armies

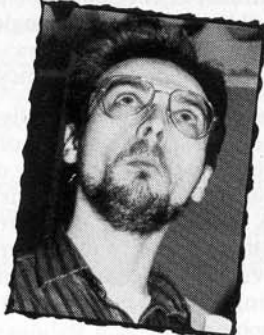

Warhammer Armies, the latest escapee from the Warhammer stable, has taken quite a while to design; a process involving more than a little discussion, some shouting, occasional outbursts

of violence and considerable mental decay. Chewed carpets aside, the results have proved more than worth the energy expended. The authors were last seen sitting on the studio's huge padded sofa and looking smug. The experience of *Ravelling Hordes* (re-lived by Richard Halliwell under hypnotherapy) proved invaluable. So did the welcome comments of the many gamers who felt prompted to write letters explaining why their armies should be allowed armour plated mammoth carts, and such like.

ORCS & GOBLINS

The list presented on the following pages is by means of a taster, an example of the general layout and manifold choices we've cunningly engineered into **Warhammer Armies**. The list is not literally as it appears in the book (we've taken out some cross-references that might lead to some confusion with the list in article form). Players already familiar with *Ravelling Hordes* won't need to be told how to use the list. Other players (why didn't you buy RH then, eh?) will have to muddle through until the book comes out.

Okay, okay, we'll tell you. This list (like the others in **Warhammer Armies**) has been designed to allow players to select Warhammer Armies of equal points values. We based the lists on forces averaging 3000 points, but they'll do fine for armies between 2000 and 5000 points. The lists limit the proportion of the army's points value that may be spent on heroes, wizards, ordinary troops, allies, mercenaries and hosts.

Each of these varies from army to army, giving each force its own unique flavour. In the case of Goblins it's better not to say what this flavour is exactly, but obviously it's fairly unpleasant and probably compost related. You will notice that certain elements of the army are compulsory, thus delineating the broad nature of the force - so all goblinoid armies have at least a few Gobbos, for example. In addition all armies must have a General - a character model to lead the force. In the case of the list presented here, this will be the loudest, meanest and most foul-tempered creature possible (ie, the character with the highest *Leadership* characteristic). Although the army contains

mandatory elements, it is possible to equip each of these in slightly different ways, paying additional points as indicated for each entry. The same applies to the non-compulsory troops, which may be variously armed and armoured to the player's tastes. No two armies of equal points value need be the same, even though they may be chosen from the same list.

As well as the troops, heroes and wizards who make up the basic army, players can employ mercenaries or call upon allies to build up their force. **Warhammer Armies** contains all the details needed to incorporate these additional troops into your army - including rules for bribing the enemy's mercenaries not to fight! You'll find full mercenary and ally details in the book itself. If an army contains a wizard (and if you don't choose at least one, you've lost before you start), it may include magically bound creatures in the form of a host (see the *Warhammer Bestiary* for details of magical binding).

Without **Warhammer Armies**, players wishing to assemble a goblinoid army should refer to the **Warhammer Fantasy Battle** rulebook to obtain details of magical weapons, standards, and so on. *Ravelling Hordes* veterans will notice that we've changed the old system somewhat. Not least of these changes are the reduction in points paid for elites, and the scrapping of the points cost modifiers for characters' weapons and equipment. These subtle changes were made with competitive gaming in mind, and will no doubt be welcomed by ambitious *Warhammer* Generals.

Nigel Stillman & Rick Priestley

ORCS & GOBLINS

Goblinoids have some claim to be the most numerous and the most debased group of creatures in the entire world. These creatures (ie, Orcs, Goblins, Half-Orcs, Savage Orcs, Black Orcs, and Snotlings) live in large, dispersed tribes, often occupying several settlements. Although each race has its own distinct tribes, the larger goblinoids nurture a slave-class of the less powerful races. For this reason it is appropriate to consider Orcs and Goblins as forming a single army type. Orc armies always include a few Goblin lackeys - probably brought along to do the jobs even Orcs don't fancy much!

Goblinoid armies are generally led by Orcs or Half-Orcs, who are the biggest and cleverest of their kin. The rank and file of the army consist of a mixture of Orcs, Goblins, Half-Orcs and even Snotlings. Because of this wide variety of races, an army of this type will have many troop types, from weakly armed Snotlings to deadly Orc boar riders. And then, of course, captured battle-engines are often put to good use, while the swift and dangerous Goblin chariots can mow down the enemy like so much grass.



With this wide range of weaponry and varied troops it might seem that a large force of goblinoids is unstoppable. However, this assumption ignores the major bane of a goblinoid commander - the violently devious nature of these creatures. Animosity between rival tribes and races can be a nightmare, and makes it important to think about the army's disposition very carefully. With a little forethought, however, a goblinoid army is surely one of the most potent available to the Warhammer player.

Goblinoids form into fighting units under powerful or influential leaders. Rivalry between units is great, producing a strong sense of unit identity and loyalty. Goblinoids don't wear uniforms, but units often adopt a standard colour - usually brown or red. Units sometimes have unit standards which they make as big and impressive as possible by decorating them with gory symbols of death and destruction, not the least being the putrifying remains of defeated enemies and rivals. Shields are decorated in simple circular patterns and with crude (sometimes vulgar) designs.

ORC AND GOBLIN ARMY

	M	WS	BS	S	T	W	I	A	Ld	Int	Cl	WP	Pts
Goblin	4	2	3	3	3	1	2	1	5	5	5	5	2½
5 Hero	4	3	4	4	3	1	3	2	5	5	5	5	15
10 Hero	4	4	4	4	4	2	3	3	6+1	5	5	5	28
15 Hero	4	4	4	4	4	3	4	3	7+2	5	6+1	6+1	40
20 Hero	4	5	4	4	4	4	5	4	8+3	5	6+1	6+1	53
25 Hero	4	5	5	4	4	4	5	4	8+3	7+2	7+2	7+2	65
5 Wizard	4	3	3	4	3	1	2	1	5	6+1	6+1	6+1	45
10 Wizard	4	3	3	4	3	2	3	1	6+1	7+2	6+1	7+2	58
15 Wizard	4	4	3	4	4	3	3	1	7+2	7+2	7+2	7+2	115
20 Wizard	4	4	4	4	4	4	4	1	7+2	8+3	7+2	8+3	188
25 Wizard	4	5	5	4	4	4	5	1	8+3	8+3	8+3	8+3	275

Base size: Infantry 20mmx20mm; Wolf Riders 25mmx25mm

	M	WS	BS	S	T	W	I	A	Ld	Int	Cl	WP	Pts
Half-Orc	4	3	3	3	3	1	3	1	7	6	7	7	5
5 Hero	4	4	4	4	3	1	4	2	7	6	7	7	30
10 Hero	4	5	4	4	4	2	4	3	8+1	6	7	7	55
15 Hero	4	5	4	4	4	3	5	3	9+2	6	8+1	8+1	80
20 Hero	4	6	4	4	4	4	6	4	10+3	6	8+1	8+1	105
25 Hero	4	6	5	4	4	4	6	4	10+3	8+2	9+2	9+2	150
5 Wizard	4	4	3	4	3	1	3	1	7	7+1	8+1	8+1	60
10 Wizard	4	4	3	4	3	2	4	1	8+1	8+2	8+1	9+2	85
15 Wizard	4	5	3	4	4	3	4	1	9+2	8+2	9+2	9+2	155
20 Wizard	4	5	4	4	4	4	5	1	9+2	9+3	9+2	10+3	240
25 Wizard	4	6	5	4	4	4	6	1	10+3	9+3	10+3	10+3	340

Base size: Infantry 20mmx20mm

	M	WS	BS	S	T	W	I	A	Ld	Int	Cl	WP	Pts
Orc	4	3	3	3	4	1	2	1	7	5	7	7	5½
5 Hero	4	4	4	4	4	1	3	2	7	5	7	7	33
10 Hero	4	5	4	4	5	2	3	3	8+1	5	7	7	61
15 Hero	4	5	4	4	5	3	4	3	9+2	5	8+1	8+1	88
20 Hero	4	6	4	4	5	4	5	4	10+3	5	8+1	8+1	116
25 Hero	4	6	5	4	5	4	5	4	10+3	7+2	9+2	9+2	143
5 Wizard	4	4	3	4	4	1	2	1	7	6+1	8+1	8+1	63
10 Wizard	4	4	3	4	4	2	3	1	8+1	7+2	8+1	9+2	91
15 Wizard	4	5	3	4	5	3	3	1	9+2	7+2	9+2	9+2	163
20 Wizard	4	5	4	4	5	4	4	1	9+2	8+3	9+2	10+3	251
25 Wizard	4	6	5	4	5	4	5	1	10+3	8+3	10+3	10+3	353

Base size: Infantry 25mmx25mm; Boar/Giant Wolf Riders 25mmx50mm

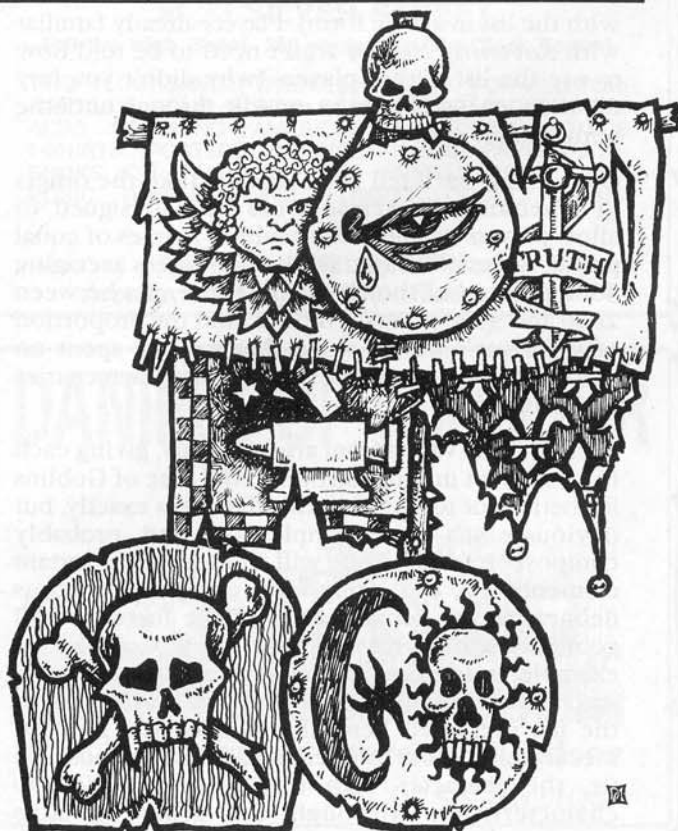

CHARACTER MODELS

Character models are *Heroes* and *Wizards* (usually called shamans amongst goblinoids). The player may spend up to a third of the army's total points value on character models. An Orc & Goblin army must have at least 1 character model (ie, the General). It is not necessary to include Wizards if you do not wish to do so, but the maximum permitted number is 5.

General: the army must be led by a General who will be the character model with the highest *leadership* characteristic.

Army Standard: the army is allowed one army standard which must be carried by a character model and paid for from the character model points allowance. Army standards cost 50 points.

Races: character models may be either Orcs, Half Orcs, Goblins, Black Orcs, or Savage Orcs. The player is allowed a free choice of which to select, so an army could, for example, contain only Orc character models, only Half Orcs or, more commonly, a mixture of all races.

Riding in Chariots: character models may ride in chariots included as part of the army's 'rank and file' points allowance. This does not affect either the points value of the chariot or the character. Chariots carrying characters can be treated as separate units of 1 model.

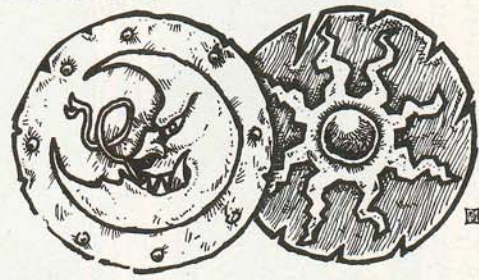

Points: the costs given for characters are for a basic, unarmoured model with a hand weapon. Characters should be provided with armament as depicted on the model and selected from the following list. If the model is carrying a piece of equipment *not* mentioned on the table, it may be ignored. All the items on the table, except for *riding animals* and *war beasts*, cost half price for Goblin characters.

	M	WS	BS	S	T	W	I	A	Ld	Int	Cl	WP	Pts
Savage Orc	4	3	3	3	4	1	2	1	7	5	7	7	5½
5 Hero	4	4	4	4	4	1	3	2	7	5	7	7	33
10 Hero	4	5	4	4	5	2	3	3	8+1	5	7	7	61
15 Hero	4	5	4	4	5	3	4	3	9+2	5	8+1	8+1	88
20 Hero	4	6	4	4	5	4	5	4	10+3	5	8+1	8+1	116
25 Hero	4	6	5	4	5	4	5	4	10+3	7+2	9+2	9+2	143
5 Wizard	4	4	3	4	4	1	2	1	7	6+1	8+1	8+1	63
10 Wizard	4	4	3	4	4	2	3	1	8+1	7+2	8+1	9+2	91
15 Wizard	4	5	3	4	5	3	3	1	9+2	7+2	9+2	9+2	163
20 Wizard	4	5	4	4	5	4	4	1	9+2	8+3	9+2	10+3	251
25 Wizard	4	6	5	4	5	4	5	1	10+3	8+3	10+3	10+3	353

Base size: Infantry 25mmx25mm; Boar/Giant Wolf riders 25mmx50mm

	M	WS	BS	S	T	W	I	A	Ld	Int	Cl	WP	Pts
Black Orc	4	4	3	4	4	1	2	1	8	5	7	7	7
5 Hero	4	5	4	5	4	1	3	2	8	5	7	7	42
10 Hero	4	6	4	5	5	2	3	3	9+1	5	7	7	77
15 Hero	4	6	4	5	5	3	4	3	10+2	5	8+1	8+1	112
20 Hero	4	7	4	5	5	4	5	4	10+3	5	8+1	8+1	147
25 Hero	4	7	5	5	5	4	5	4	10+3	7+2	9+2	9+2	217
5 Wizard	4	5	4	5	4	1	2	1	8	6+1	8+1	8+1	72
10 Wizard	4	5	4	5	4	2	3	1	9+1	7+2	8+1	9+2	107
15 Wizard	4	6	4	5	5	3	3	1	10+2	7+2	9+2	9+2	187
20 Wizard	4	6	5	5	5	4	4	1	10+2	8+3	9+2	10+3	282
25 Wizard	4	7	5	5	5	4	5	1	10+3	8+3	10+3	10+3	427

Base size: Infantry 25mmx25mm; Boar/Giant Wolf riders 25mmx50mm

	M	WS	BS	S	T	W	I	A	Ld	Int	Cl	WP	Pts
SNOTLING	4	2	2	1	1	3	3	3	4	4	4	4	25

Base size: Infantry 40mmx40mm for up to 9 figures

	M	WS	BS	S	T	W	I	A	Ld	Int	Cl	WP	Pts
TROLL	6	3	1	5	4	3	1	3	4	4	6	6	65

Base size: 40mmx40mm

Alignment: Orc and Goblin armies are Evil.

Psychology: Units of Orcs and Goblins are subject to *animosity* against other goblinoid units. Goblins *bate* Dwarfs and Gnomes and *fear* units of Elves of more than half their own numeric strength. Savage Orcs are subject to *frenzy*.

ARMY SELECTION

Force	Minimum	Maximum
Rank & File models	½ Army's total PV	Whole Army less 1 Hero
Character models	1 Hero	⅓ Army's total PV
Heroes	1 model	⅓ Army's total PV
Wizards	0	5 models
Allies	0	⅓ Army's total PV
Mercenaries	0	⅓ Army's total PV
Monstrous Host	0	¼ Army's total PV

Item	Points cost per character model	Item	Points cost per character model
Close Combat Weapons		Armour	
Additional hand weapon	1	Shield	1
Double-handed weapon	2	Light armour	2
Lance	2	Heavy armour	3
Net	1	Riding Animals	
Spear	1	Boar (Goblins only)	6
		Giant wolf mount	8
		War Boar mount (not Goblins)	16
Missile Weapons		War Beasts	
Bow	2	Giant Spider (Goblins only)	45
Crossbow (not Goblins)	3	Wyvern (not Goblins)	180
Javelin	1		
Short bow	1		
Throwing axes or spears	1		
Throwing knives or darts	1		

Steve Jackson

presents

FIRST

Fantasy Interactive Scenarios by Telephone

“Who is this who dares enter the domain of Kaddis-Ra? Haaaaa! Punny human. You would pit your meagre strength against the forces of darkness? Savour these moments, miserable mortal, for they will be your last on earth!”

FIRST

Is planned for release in July

Watch out for ads in White Dwarf & Video Games Magazines.

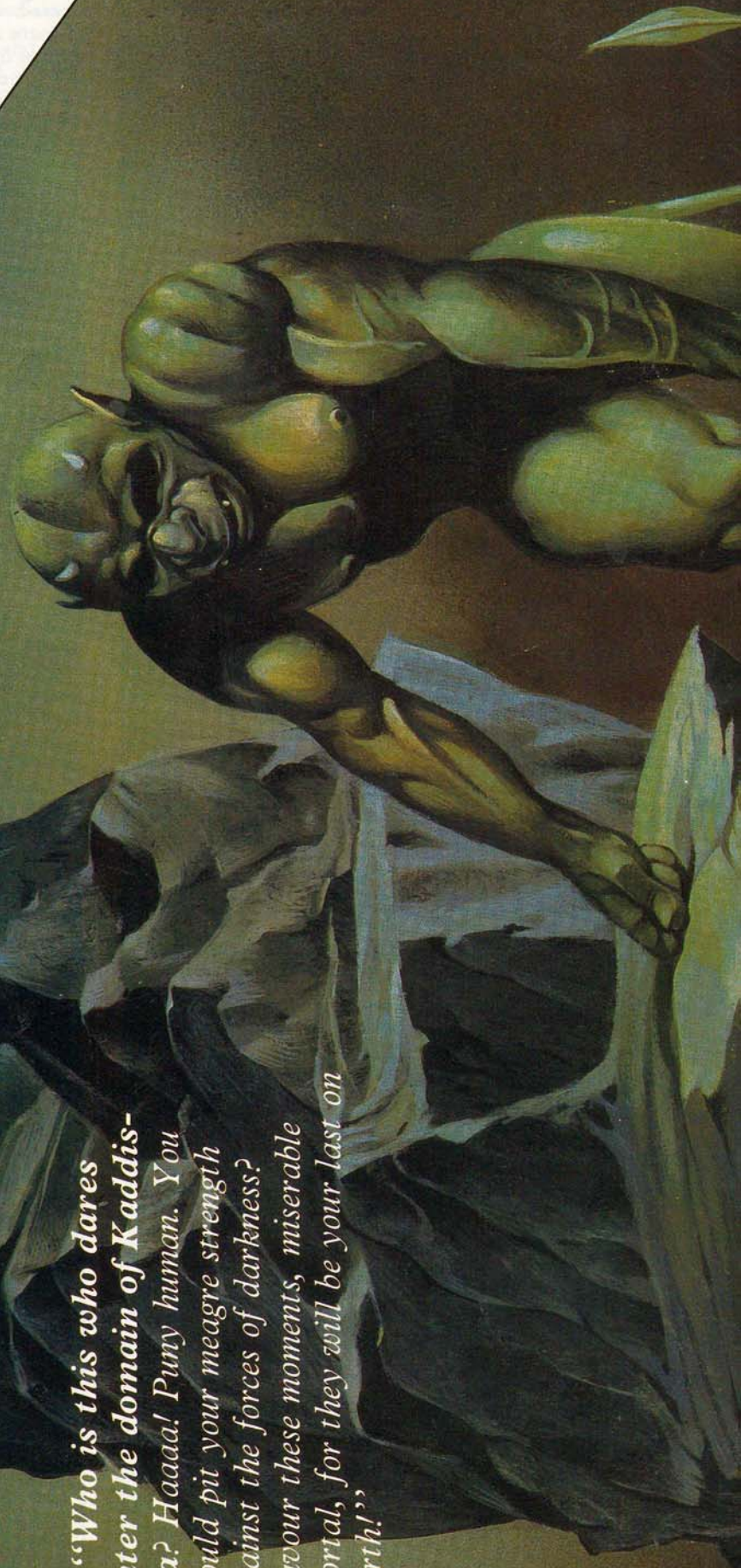

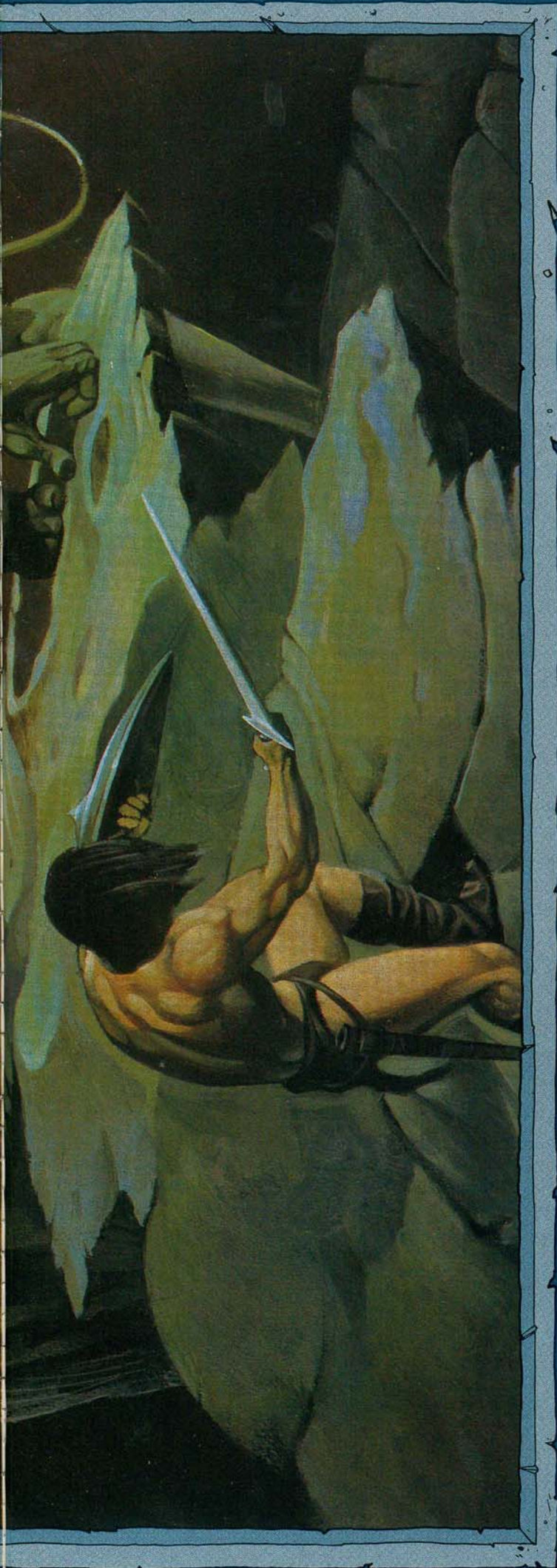

In days long ago, when the gods of law and chaos clashed in their eternal struggle for celestial supremacy, the world was their battleground. When the tide turned against the gods of chaos they retaliated by sending seven Demon Princes to destroy the forces of good.

“One such Prince was **Kaddis-Ra** who founded his empire beneath the ruins of Castle Mammon. Kaddis-Ra’s plan was to undermine the very foundations of the forces of good by tempting youthful nobles into his underworld.

These young warriors and adventurers, destined to be the future generals and rulers of the lawful lands, were particularly vulnerable. He played on the qualities of youth: their spirits of adventure,

driving ambition and their zeal for excitement, fame and fortune. Many young adventurers entered his dungeons; very few returned.

*Do you dare to try your luck in this deadly PlunderQuest in Kaddis-Ra’s underworld? There are great riches to be discovered (including **REAL GOLD PIECES** from our monthly competitions), but beware the Demon Prince’s undead legions and deadly traps. In order to succeed you must enter the dungeons, gather as much treasure as you are able to discover, find the Escape Route and return to the Adventurer’s Guild in Beckbridge to register your score of Gold Pieces.*

HINTS ON PLAY

- KEEP A PENCIL AND PAPER TO TRACK YOUR CHOICES.
- COMBAT MONSTERS BY DIALLING NUMBERS ON YOUR PHONE.
- DIAL 9 TO HEAR YOUR CHARACTER STATUS REPORT (inventory, provisions, stamina and option to send your character into LIMBO.)
- DIAL 0 TO REPEAT MESSAGES.
- SEND FOR YOUR ADVENTURER’S PACK TODAY TO: F.I.S.T. c/o Commercial Limited, P.O. Box 530, 24 Earls Court Road, London W8 6DA

DIAL

0898 800 876

CHARGES

Calls are charged at 25p per minute between 6pm - 8pm and weekends, or 38p per minute peak and standard times.

Heroes

The army may contain a maximum of 20 hero models. The maximum number of heroes available at each level is given on the table below.

Maximum availability	Points per model				
	Orc	Half Orc	Goblin	Black Orc	Savage Orc
6 level 5 heroes	33	30	15	42	33
5 level 10 heroes	61	55	28	77	61
4 level 15 heroes	88	80	40	112	88
3 level 20 heroes	116	105	53	147	116
2 level 25 heroes	143	150	65	217	143

Revered Heroes

The four goblinoid races all use titles to distinguish their mightiest warriors. These, unlike other races, tend to vary from tribe to tribe. Here are selection of suitable titles.

Spiker, Slasher, Spitter, Biter, Nobbler, Splitter, Crumpa, Gnasher, Hacker, Boss, Gaffer, Gutter, Stompa, Murderer, Ripper, Smasha, Killer, Cruncher.

Champions

Level 5, 10 and 15 heroes must be assigned to specified units as leaders unless designated as the Army Standard Bearer. These 'hero-leaders' are referred to as **champions**. Champions are part of the unit they are assigned to and cannot leave it (see **WFB**, p93). *Champions* are normally of the same race as their unit, but Black Orcs may lead any goblinoid unit, Orcs may lead any goblinoid unit other than Black Orcs, and Half-Orcs may lead any goblinoid unit other than Black Orcs and Orcs.

Level 20 or 25 heroes may be assigned to specified units as *champions* if the player wishes. Alternatively, they may be left as independent characters, free to associate with any unit in the normal way (see **WFB**, p90).



Wizards

The army may contain a maximum of 5 shamans or wizards. Shamans of any level may be assigned to specified units as *champions*, or may be left as independent characters, free to associate with any unit in the normal way (see **WFB**, p90). The maximum number of Shaman wizards and their magic level is given below.

Maximum availability	Points per model				
	Orc	Half Orc	Goblin	Black Orc	Savage Orc
3 level 5 wizards	63	60	45	72	63
2 level 10 wizards	91	85	58	107	91
1 level 15 wizard	163	155	115	187	163
1 level 20 wizard	251	240	188	282	251
1 level 25 wizard	353	340	275	427	353

Revered Shamans

As with heroes, goblinoids use level titles to describe their Shamans. Goblinoid tribal shamans' titles vary from tribe to tribe. Some suitable titles for tribal shamans are:

Bone-caster, Chanter, Wailer, Screacher, Screamer, Spook-talker, Dung-fumbler, Gizzarder.

Generating Spells

The number of spells available to each level of wizard is as follows.

Character Level	Magic Level	Number of spells of level			
		1	2	3	4
5	1	3	0	0	0
10	1	6	0	0	0
15	2	6	3	0	0
20	3	6	3	3	0
25	4	6	3	3	3

All spells are generated randomly from the Spell Index (**WFB**, p150). Except where noted below, spells should be generated from the appropriate spell level of the Battle Magic chart.

Goblin wizards may generate up to one Elemental, one Necromantic, one Illusionist and up to two Daemonic spells from each of the levels available to them instead of Battle Magic spells of the same level.

Orc, Half Orc and Savage Orc wizards may generate one Elemental, Necromantic, Illusionist or Daemonic spell from each of the levels available to them instead of a Battle Magic spell of the same level.

Magic Items for Characters

Characters may carry magical items paying the points indicated on the *Magic Items Chart*, **WFB**, pp182-186. These are paid for from the character model points allowance and selected from the following list.

Any character model may carry one magic weapon with up to one magic attribute for every 5 'levels' of the character (ie, a level 5 character may carry a weapon with one attribute, a level 15 character may carry a weapon with three, etc).

One character model may be equipped with magic armour.

The army standard may have one magical ability.

◀ RANK & FILE ▶

A minimum of half of the army's total points value must be spent on Rank & File troops. All units are assumed to have a *leader* with the same profile as the rest of the unit.

Any unit may be given a unit standard bearer and/or a musician. Standard bearers and musicians are equipped in exactly the same way as the rest of the unit and cost double the points value of a basic trooper.

Any unit indicated may convert an ordinary standard into a magic standard with a single ability. The ability may have a points value up to the amount indicated. The specific ability must be chosen and noted down before the game (see **WFB**, p186).

Any unit indicated may convert an ordinary musical instrument into a magic instrument with a single ability. All magical instruments cost an extra 25 pts as indicated below. The specific ability must be chosen and noted down before the battle (see **WFB**, p186).

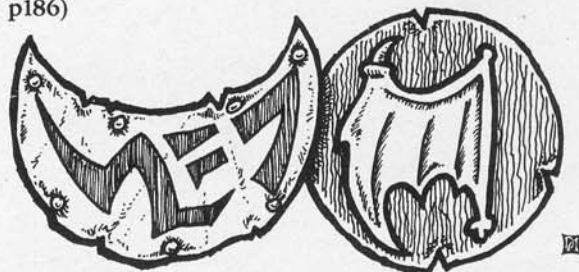

0-10 SNORTAS

ORC RIDER	M	WS	BS	S	T	W	I	A	Ld	Int	Cl	WP
+1 SHOCK ELITE	-	4	3	3	4	1	2	1	7	5	7	7
WAR BOAR	7	4	0	3	4	-	3	1	-	-	-	-



MODELS PER UNIT:	10
POINTS PER MODEL:	27
WEAPONS:	HAND WEAPONS
ARMOUR:	LIGHT ARMOUR & SHIELD
OPTIONS	
ONE UNIT MAY HAVE:	
A MAGIC STANDARD	100

Naturally, some really hard and bad Orcs choose to ride into battle on war-boars, such élites are known as 'Snortas'.

0-30 BIGUNS

ORCS	M	WS	BS	S	T	W	I	A	Ld	Int	Cl	WP
+1 SHOCK ELITE	4	4	3	3	4	1	2	1	7	5	7	7



MODELS PER UNIT:	10-20
POINTS PER MODEL:	9½
WEAPONS:	HAND WEAPON
ARMOUR:	LIGHT ARMOUR & SHIELD
OPTIONS	
ANY UNIT MAY HAVE:	
ADDITIONAL HAND WEAPON	1
DOUBLE-HANDED WEAPON	2
SPEARS	1
ONE UNIT MAY HAVE:	
A MAGIC STANDARD	100

Foremost among Orc warrior society are the 'Big Uns'. These big, tough, fierce Orcs always grab the best wargear when looting the battlefield.

0-30 GRUNTAS

ORC RIDER	M	WS	BS	S	T	W	I	A	Ld	Int	Cl	WP
ORC RIDER	-	3	3	3	4	1	2	1	7	5	7	7
WARBOAR	7	4	0	3	4	-	3	1	-	-	-	-



MODELS PER UNIT:	10-20
POINTS PER MODEL:	19
WEAPONS:	HAND WEAPON
ARMOUR:	NONE
OPTIONS	
ANY UNIT MAY HAVE:	
SPEARS	2
SHORT BOWS	2
SHIELDS	2
LIGHT ARMOUR	4

These are Orc warriors who ride war-boars. The stubborn, vicious nature of these beasts and their wicked tusks are much admired by Orcs.

20-100 BOYZ

ORC	M	WS	BS	S	T	W	I	A	Ld	Int	Cl	WP
ORC	4	3	3	3	4	1	2	1	7	5	7	7



MODELS PER UNIT:	10-30
POINTS PER MODEL:	8½
WEAPONS:	HAND WEAPON
ARMOUR:	LIGHT ARMOUR & SHIELD
OPTIONS	
ANY UNIT MAY HAVE:	
HALBERDS	2
SPEARS	1
ONE UNIT MAY HAVE:	
DOUBLE-HANDED WEAPON	2
A MAGIC STANDARD	50

The bulk of the Orc warriors are known in goblinoid society as 'da Boyz'.

0-6 ORC BATTLE CHARIOTS

LIGHT CHARIOT	M	WS	BS	S	T	W	I	A	Ld	Int	Cl	WP
ORC CREW (2)	4	3	3	3	4	1	2	1	7	5	7	7
GIANT WOLF (2)	9	4	0	3	3	1	3	1	3	4	4	4

MODELS PER UNIT:
1-6 CHARIOTS

POINTS PER MODEL:
62

WEAPONS:
HAND WEAPON

ARMOUR:
LIGHT ARMOUR

OPTIONS

ANY CREW MAY HAVE:

SHIELD 2
SHORT BOW 2

ONE CHARIOT UNIT MAY HAVE:

A MAGIC STANDARD 100
ANY CHARIOT MAY HAVE:
SCYTHED WHEELS 20

Going into battle in a chariot does much for the prestige of an Orc warrior. If the chariot warrior has a shield, both crew count as shielded and the points value has been calculated accordingly. Note also that chariot crews are considered to be armed with hand weapons irrespective of weapons carried by the model.

20-60 ARRER BOYZ

ORC	M	WS	BS	S	T	W	I	A	Ld	Int	Cl	WP
ORC	4	3	3	3	4	1	2	1	7	5	7	7



MODELS PER UNIT:	10-30
POINTS PER MODEL:	7½
WEAPONS:	BOW & HAND WEAPON
ARMOUR:	NONE
OPTIONS	
ANY UNIT MAY HAVE:	
SHIELDS	1
LIGHT ARMOUR	2
ONE UNIT MAY SUBSTITUTE:	
BOWS FOR CROSSBOWS	2

The 'Arrer Boyz' are Orc warriors who favour the bow, or occasionally the crossbow, so they can slay the enemy from a safe distance.

0-50 GOBBO WULFBOYZ

	M	WS	BS	S	T	W	I	A	Ld	Int	Cl	WP
GOBLIN WOLF RIDER	—	2	3	3	3	1	2	1	5	5	5	5
WOLF	9	4	0	3	3	—	3	1	—	—	—	—



MODELS PER UNIT: 5-20

POINTS PER MODEL: 9

WEAPONS: HAND WEAPON

ARMOUR: NONE

OPTIONS

ANY UNIT MAY HAVE:
 SHORT BOWS..... 1
 SHIELDS..... 1
 LIGHT ARMOUR..... 2
 SPEARS..... 1

These are Goblin warriors who ride wolves specially tamed, bred and half-starved to turn them into ferocious drooling battle-mounts.

0-6 GOBLIN BATTLE CHARIOTS

	M	WS	BS	S	T	W	I	A	Ld	Int	Cl	WP
LIGHT CHARIOT												
GOBLIN CREW (2)	4	2	3	3	3	1	2	1	5	5	5	5
GIANT WOLF (2)	9	4	0	3	3	1	3	1	3	4	4	4
WARBOAR	7	4	0	3	4	1	3	1	3	4	4	4

MODELS PER UNIT:
1-6 CHARIOTS

POINTS (Inc. crew):
46



WEAPONS: HAND WEAPON
ARMOUR: LIGHT ARMOUR

OPTIONS
ANY CHARIOT MAY HAVE:
 SCYTHED WHEELS..... 20
ANY CREW MAY HAVE:
 BOW..... 2
 SHIELDS..... 2

If the chariot warrior has a shield, both crew count as shielded and the points value has been calculated accordingly. Note also that chariot crews are considered to be armed with hand weapons irrespective of weapons carried by the model.

20-200 STICKAS

	M	WS	BS	S	T	W	I	A	Ld	Int	Cl	WP
GOBLINS	4	2	3	3	3	1	2	1	5	5	5	5



MODELS PER UNIT: 20-50

POINTS PER MODEL: 3

WEAPONS: SHORT BOW & HAND WEAPON

ARMOUR: NONE

OPTIONS

ANY UNIT MAY HAVE:
 SHIELDS..... ½
 LIGHT ARMOUR..... 1

These are Goblin archers who prove quite dangerous when deployed in large numbers.

20-200 GOBBO'S

	M	WS	BS	S	T	W	I	A	Ld	Int	Cl	WP
GOBLINS	4	2	3	3	3	1	2	1	5	5	5	5



MODELS PER UNIT: 20-100

POINTS PER MODEL: 3

WEAPONS: HAND WEAPON & JAVELINS

ARMOUR: NONE

OPTIONS

ANY UNIT MAY HAVE:
 SPEARS..... ½
 SHIELDS..... ½
 LIGHT ARMOUR..... 1

ONE UNIT MAY HAVE:
 DOUBLE-HANDED WEAPONS..... 1
 HALBERDS..... 1

These form the bulk of the Goblin warriors. Goblins form a deprived and abused underclass in goblinoid society and are deployed with callous ruthlessness by Orc war-leaders.

0-3 GOBLIN FANATICS PER GOBLIN INFANTRY UNIT

FOR SPECIAL RULES ON GOBLIN FANATICS SEE WFB, p98



MODELS PER UNIT: 0-3

POINTS PER MODEL: 30

WEAPONS: BALL & CHAIN

ARMOUR: NONE

These drug-crazed followers of an insane Goblin cult wield a huge ball-and-chain. The number of Goblin fanatics allowed depends on the total number of Goblin infantry units in the army. The fanatics are 'bidden' in Goblin units. Up to three fanatics may be bidden in each Gobbo or Sticka unit, see WFB, p98.

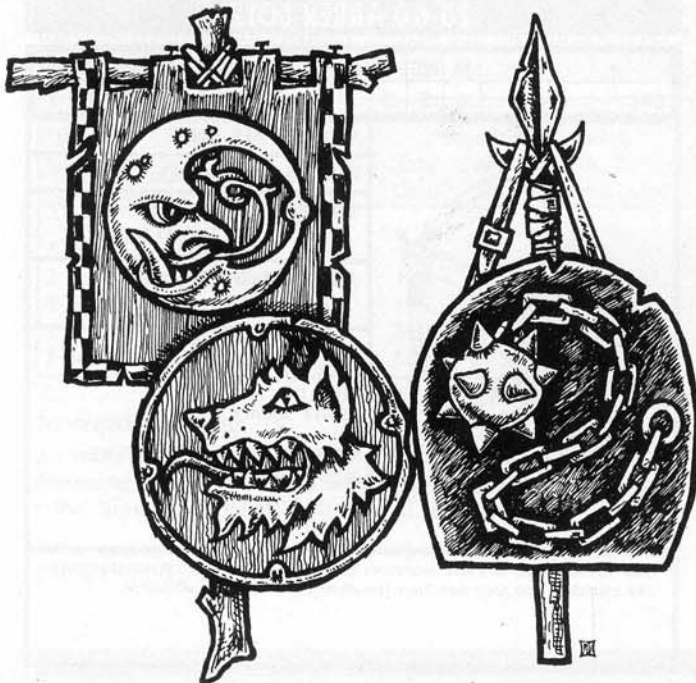

0-30 SAVAGE BOYZ

	M	WS	BS	S	T	W	I	A	Ld	Int	Cl	WP
SAVAGE ORC	4	3	3	3	4	1	2	1	7	5	7	7



MODELS PER UNIT: 10-30
POINTS PER MODEL: 5½
WEAPONS: HAND WEAPON
ARMOUR: NONE

OPTIONS
 ANY UNIT MAY HAVE:
 SHIELDS 1
 ONE UNIT MAY HAVE:
 ADDITIONAL HAND WEAPON... 1
 DOUBLE-HANDED WEAPON..... 2
 A MAGIC STANDARD..... 50

Primitive Orc tribes dwelling in remote forest or mountainous regions are known as 'Savage Orcs'. They use crude weaponry and wear simple bide clothing, if any at all. Savage Orcs are subject to frenzy.

0-40 BLACK ORCS

	M	WS	BS	S	T	W	I	A	Ld	Int	Cl	WP
BLACK ORCS	4	4	3	4	4	1	2	1	8	5	7	7



MODELS PER UNIT: 5-10
POINTS PER MODEL: 9
WEAPONS: HAND WEAPON
ARMOUR: LIGHT ARMOUR

OPTIONS
 ANY UNIT MAY HAVE:
 DOUBLE-HANDED WEAPONS.... 2
 SHIELDS 1
 ONE UNIT MAY HAVE:
 HALBERDS..... 2
 A MAGIC STANDARD..... 50

Black Orcs come from the very heart of the Darklands and are the largest and most aggressive goblinoids yet known.

0-20 SAVAGE ARRERS

	M	WS	BS	S	T	W	I	A	Ld	Int	Cl	WP
SAVAGE ORC	4	3	3	3	4	1	2	1	7	5	7	7



MODELS PER UNIT: 10-20
POINTS PER MODEL: 7½
WEAPONS: BOW & HAND WEAPON
ARMOUR: NONE

OPTIONS
 ANY UNIT MAY HAVE:
 SHIELDS 1
 ONE UNIT MAY HAVE:
 ADDITIONAL HAND WEAPON... 1

These are Savage Orc archers, who use flint-tipped arrows. Like all Savage Orcs, they are subject to frenzy.

0-40 SNOTGLINGS

	M	WS	BS	S	T	W	I	A	Ld	Int	Cl	WP
SNOTLING BASE	4	2	2	1	1	3	3	3	4	4	4	4



MODELS PER UNIT: 5-20 bases
POINTS PER MODEL: 25
WEAPONS: HAND WEAPON
ARMOUR: NONE

OPTIONS
 ANY UNIT MAY HAVE:
 SPORE WEAPONS..... 5

Snotlings are even more wretched and degenerate than Goblins. They bang around Goblin settlements pilfering scraps of food and occasionally being eaten themselves. They are nasty and spiteful.

0-20 SCABBIES

	M	WS	BS	S	T	W	I	A	Ld	Int	Cl	WP
HALF-ORCS	4	3	3	3	3	1	3	1	7	6	7	7



MODELS PER UNIT: 10-20
POINTS PER MODEL: 5
WEAPONS: HAND WEAPON
ARMOUR: NONE

OPTIONS
 ANY UNIT MAY HAVE:
 SHIELDS 1
 LIGHT ARMOUR..... 2
 ONE UNIT MAY HAVE:
 ADDITIONAL HAND WEAPON... 1
 DOUBLE-HANDED WEAPON..... 2
 SPEARS 1
 BOWS..... 2

Known as 'Scabbies', Half-orcs are despised even by other goblinoids as being 'not-proper' Goblins or Orcs. Half-orcs are cross-breeds between Goblins and other races, usually combining the worst qualities of both.

0-20 TROLLS

	M	WS	BS	S	T	W	I	A	Ld	Int	Cl	WP
TROLL	6	3	1	5	4	3	1	3	4	4	6	6



MODELS PER UNIT: 1-10
POINTS PER MODEL: 65
WEAPONS: HAND WEAPON
ARMOUR: NONE

Bands of Trolls often latch on to goblinoid tribes, attracted by the rotten carcasses, bones and refuse on which they feast. Orcs may even try to encourage them by tossing them the odd Snotling.

0-3 SNOTLING PUMP WAGONS

	M	WS	BS	S	T	W	I	A	Ld	Int	Cl	WP
SNOTLING CREW (6)	4	2	2	1	1	3	3	3	4	4	4	4

Refer to White Dwarf 88 p53 for rules

MODELS PER UNIT:
1 WAGON

POINTS (Inc. crew):
40

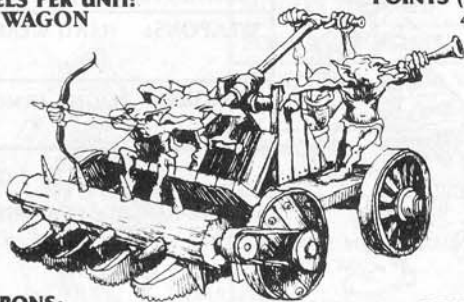

WEAPONS:
HAND WEAPON

ARMOUR:
NONE

OPTIONS
ANY WAGON MAY BE:
UPGRADED TO A HEAVY
PUMP WAGON 20

Some War Machines are acquired by goblinoids by theft from other more ingenious races and later copied (after a fashion). It is believed that Pump Wagons were originally acquired in this way.

0-2 SKULL CRUSHER STONE THROWERS

	M	WS	BS	S	T	W	I	A	Ld	Int	Cl	WP
ORC CREW (4)	4	3	3	3	4	1	2	1	7	5	7	7

	RANGE		TEMPLATE	STR	SAVE MOD.	WNDS PER HIT
	MIN	MAX				
SKULL CRUSHER	14"	64"	1"	6	-3	D4+1

MODELS PER UNIT:
1-2

WEAPONS:
HAND WEAPON

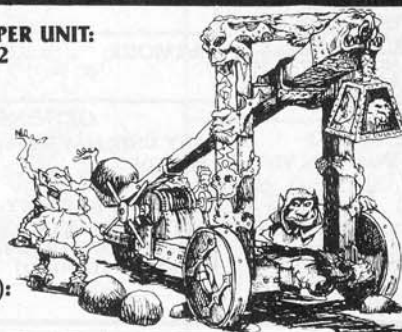

POINTS (Inc. crew):
42

ARMOUR:
NONE

Known elsewhere as a 'trebuchet'. Orcs have difficulty pronouncing foreign words, referring to such machines according to what they do to the enemy for which 'Skullcrusher' is an apt description.

Skull Crusher is a Machinery of Destruction.

0-8 SPEAR CHUKKAS

	M	WS	BS	S	T	W	I	A	Ld	Int	Cl	WP
ORC CREW (3)	4	3	3	3	4	1	2	1	7	5	7	7
GOBLIN CREW (3)	4	2	3	3	3	1	2	1	5	5	5	5

	RANGE	STRENGTH	SAVE MOD.	WOUNDS PER HIT
BOLT THROWER	48"	5	-2	1D4

MODELS PER UNIT:
1-4

POINTS (Inc. crew):
46½ (ORCS);
37½ (GOBLINS)

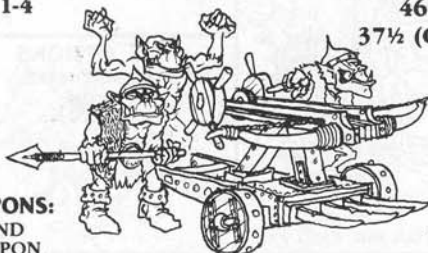

WEAPONS:
HAND WEAPON

ARMOUR:
NONE

Although goblinoids are not noted for ingenuity, it appears now and again where war and destruction are concerned. Hence these devices for skewering the enemy from a long way away.

0-2 MAN-MANGLER STONE THROWERS

	M	WS	BS	S	T	W	I	A	Ld	Int	Cl	WP
ORC CREW (6)	4	3	3	3	4	1	2	1	7	5	7	7

	RANGE		TEMPLATE	STR	SAVE MOD.	WNDS PER HIT
	MIN	MAX				
MAN-MANGLER	18"	96"	1½"	8	-5	2D4+1

MODELS PER UNIT:
1-2

POINTS (Inc. crew):
63

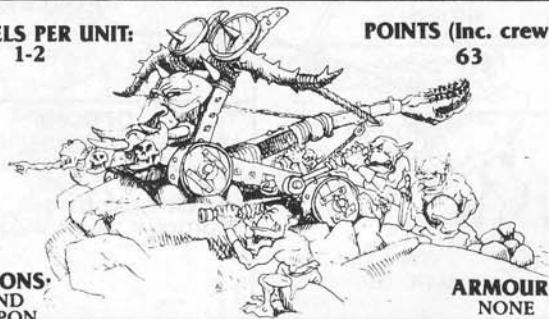

WEAPONS:
HAND WEAPON

ARMOUR:
NONE

Among Orcs, catapults of this type are known as 'manglers'. Orcs were very impressed by such weapons used against them and soon learned how to make their own.

Man-Mangler is a Machinery of Destruction.

0-2 LEAD BELCHER ORGAN GUNS

	M	WS	BS	S	T	W	I	A	Ld	Int	Cl	WP
GOBLIN CREW (3)	4	2	3	3	3	1	2	1	5	5	5	5

	RANGE	STRENGTH UP TO 12"	SAVE MOD.	WOUNDS PER HIT
LEAD BELCHER	36"	5	-3	1D3

* -1 FOR EACH 12" OF RANGE BEYOND FIRST 12"

MODELS PER UNIT:
1-2 ORGAN GUNS

POINTS PER MODEL:
102½

WEAPONS:
HAND WEAPON

ARMOUR:
NONE

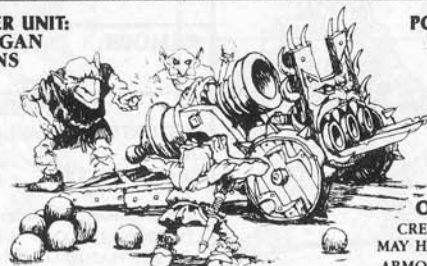

OPTIONS
CREW MODELS
MAY HAVE LIGHT
ARMOUR 1

Goblins like weapons which not only slay large numbers of enemy but do so spectacularly. They particularly enjoy the loud bang, flash and clouds of smoke issuing forth from these organ guns.

Lead Belcher is a Machinery of Destruction. Note that Lead Belcher has 4 barrels - see WFB, p112.

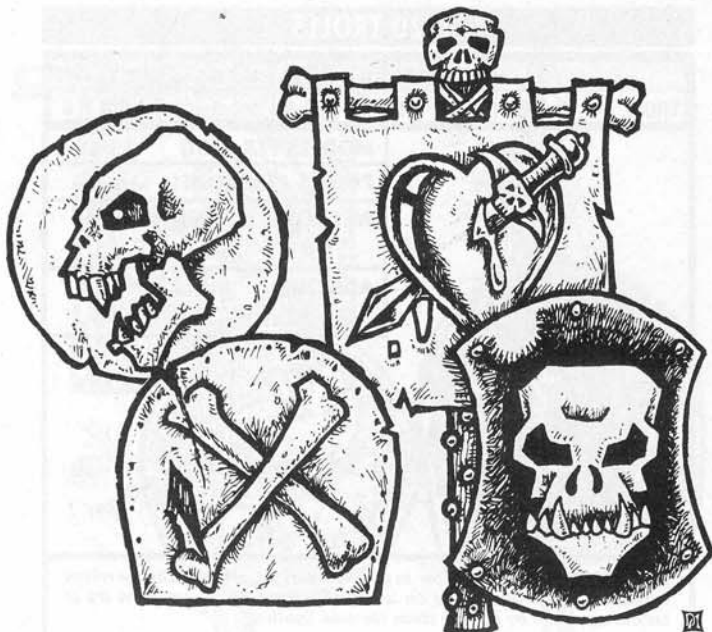

SKIRMISHERS

The following units may operate as **skirmishers** if the player wishes. Skirmishing units must be noted down before the battle. The maximum size for a skirmishing unit is 15 for foot troops and 10 for mounted troops. See **WFB**, p100 for rules on skirmishers.

Unit type	Maximum number of skirmishing units
Arrer Boyz	2
Gobbos	2
Stickas	2
Gobbo Wulfboyz	1 (if armed with bows)

BAGGAGE (see WFB, p102)

The rag-tag followers that trail after an Orc & Goblin army are vile, destitute and quarrelsome beyond even the disgustingly low standards set by Orc warriors. Heavy and multiple-dugged Orc womenfolk make up the majority of the baggage train. Their mewling off-spring, the aged, whelps and assorted hangers-on make up the rest. Those too infirm, old or stupid to be drafted into the army can make a good living by 'workin' the baggage'. Drivers, cooks, leather workers, smiths, bunko-artists, and all manner of worthless scum can profit by hanging round the army. Taking advantage of the confusion, they loot, pillage, burn and steal along with the rest of the army as well as sharing in the fun (torturing captives) and spoils (eating captives).

An Orc baggage train is represented by a single squalid wagon and 5 followers for every 1000 points worth of rank and file troops in the army. Baggage followers always include at least 1 Orc and 1 Goblin model, plus any other models of a goblinoid race represented in the army. Baggage followers are unarmoured and use improvised weapons.

ALLIES

The player may spend up to a third of the army's total points on allies. The allies must be assembled using the rules given elsewhere in *Warhammer Armies*. The player may choose allies from the following lists:

Chaos Allies
Fimir

Skaven

MERCENARIES

The player may spend up to one third of the army's total points on mercenaries. Mercenaries must be assembled using the *Mercenaries Section* detailed elsewhere in this volume. The player may choose mercenaries from the following lists:

Giants
Half Orcs
Hobgoblins

Ogres
Orcs

HOSTS (see WFB, p240)

Goblinoid shamans may bind a monstrous host. The player may spend up to one quarter of the army's total points on *hosts*. A list of permissible creatures, and their numbers is given below. The host must be assembled subject to the rules provided in the *Warhammer Bestiary*, and subject to the guidelines on *alignment* given under *How to use the Army Lists*.

The monstrous host may contain:	Points cost per model
0-40 Boars	6
0-30 Giant Bats	2
0-8 Giant Spiders	45
0-40 Giant Wolves	8
0-1 Swarms	250

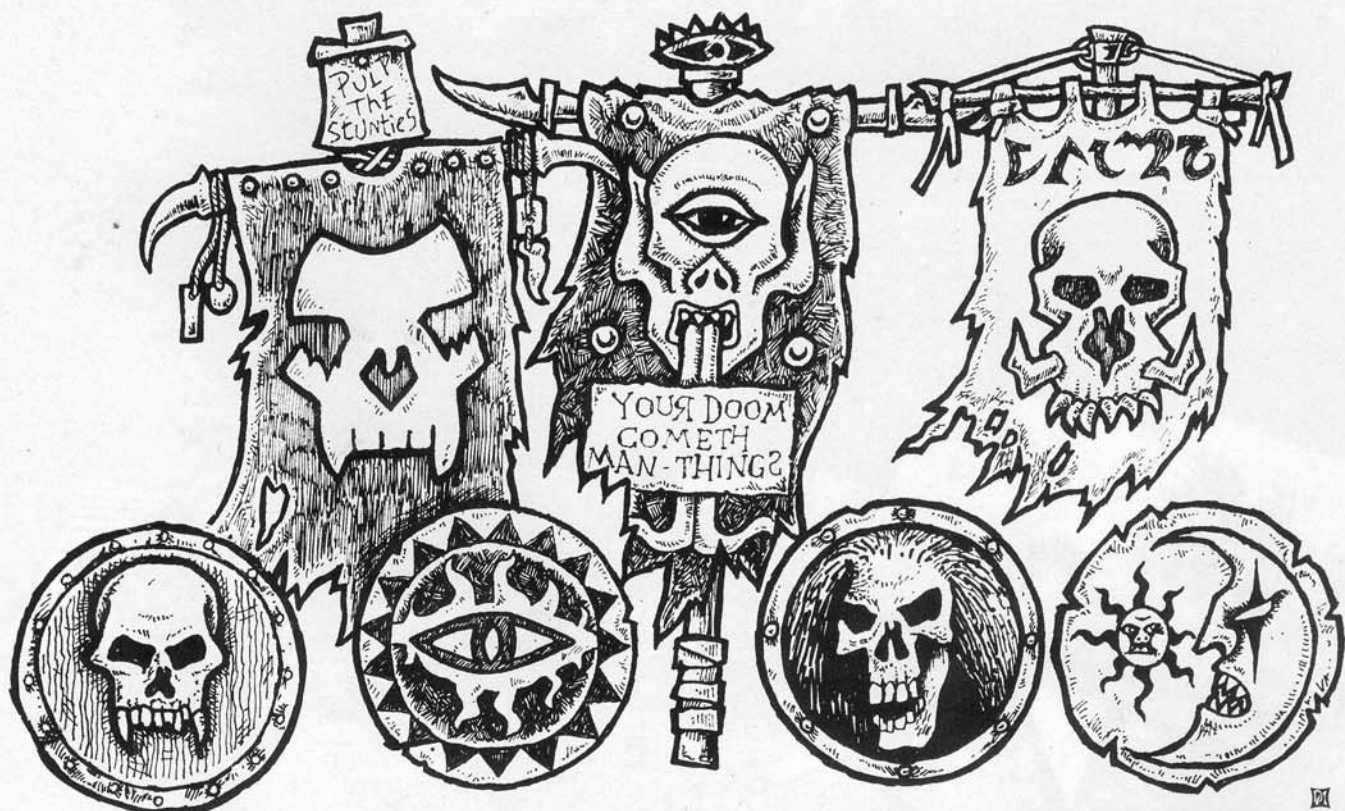

WARHAMMER FANTASY ROLE PLAY

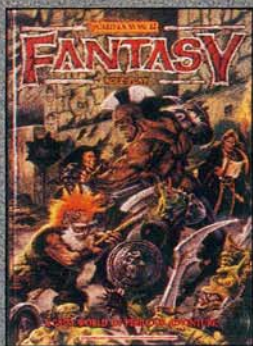

In a world as rich as the one we have created for you, you might expect to have to buy a dozen volumes of rules to see it all. Surprisingly, you don't. All the rules, magic, monsters and background come in just one book, while the steady flow of support adventures and supplements have a depth of detail and richness of atmosphere never seen before.

At the end of 1986, the most comprehensive rpg rulebook ever published opened the way to a grim world of perilous adventure. **Warhammer Fantasy Roleplay (WFRP)** is a massive, lavishly illustrated hard backed book containing everything you need for roleplaying adventures in the Warhammer world. Four player character races, over 130 skills and over 100 careers evoke the atmosphere and colour of the game's setting to a depth unequalled by any other fantasy roleplaying game.

The game's fast, easy-to-play (yet highly flexible) mechanics allow rules to be assimilated with ease, without sacrificing detail. A streamlined but colourful character advancement system provides continuous, steady development for your adventurer, rather than large rewards at arbitrary experience thresholds. Combat is fast, furious and, thanks to a detailed critical hit system, deadly.

The geography, culture and religions of the Old World are covered in fascinating depth, providing a ready-to-use and believable game world which will be familiar to all players of **Warhammer Fantasy Battle**. An extensive bestiary details over 100 intelligent races, monsters and other creatures, and the full backing of Citadel Miniatures provides figures support which no other roleplaying game can boast. **WFRP's** starter adventure, *The Oldenballe Contract*, written by **Warhammer** founding father Richard Halliwell, is designed both to help the neophyte GM and to satisfy the demands of the experienced gamer.

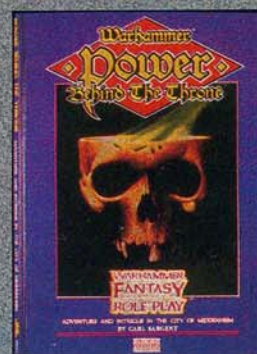
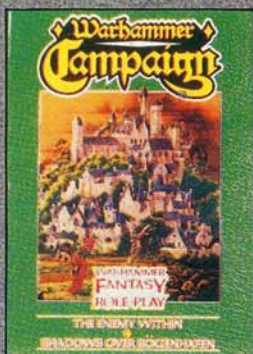
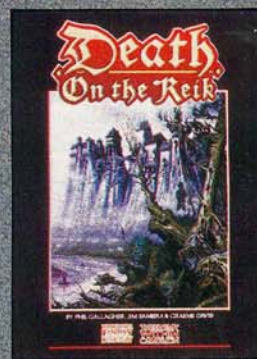

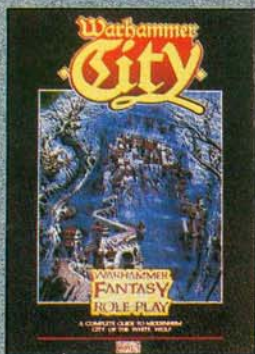

And that's not all. **Warhammer Fantasy Roleplay** is supported by an epic campaign - *The Enemy Within*. This not only provides a series of intricately designed and inter-linked adventure supplements to present you with the greatest roleplaying challenge you have ever faced, but each installment unveils more of the world - and the malignant threat of Chaos. Each part of the campaign can be played as a stand-alone adventure, and each episode is designed to demand more of your roleplaying and gamemastering skills as they develop. The adventures incorporate dozens of sub-plots and mini-adventures to allow you to customise the campaign until it's unique. Choice is something we have included all the way along.

The campaign starts off with expanded background information on The Empire - a setting different to anything you might have seen before, an early Renaissance civilisation where arcane powers of magic contrast with primitive gunpowder technology. A strange coincidence with far-reaching consequences, and a nerve-racking investigation at the highest levels of a town's society get your adventurers embroiled in a terrible struggle which provides the first hint that corruption and evil lurk where they're least expected.

From the market town of Bögenhafen, a long and eventful journey along the mighty river Reik leads you to a thundering all-action clash with the hideous occupants of a Chaos-tainted castle. In the great city of Middenheim popular unrest puts you on the trail of a plot which could bring the whole city to its knees before Chaos. Against the backdrop of the city's famous - and riotous - carnival, you must find the root of the danger and accumulate sufficient political leverage to stir the authorities into action.

The adventure supplements come packed with evocative play aids, from colour maps, player handouts and pregenerated characters to specially designed floorplans. The campaign series is complemented by accessories like floor plan packs (often containing optional rules and new adventure ideas), a character development pack (containing revised character sheets) and, of course, Citadel miniatures for every key character and creature in the **WFRP** range, making this the most exciting rpg package ever developed.

White Dwarf magazine completes Games Workshop's extensive support for **Warhammer Fantasy Roleplay**. *White Dwarf* has brought its readers the best in SF and fantasy gaming for over eleven years, and the **WFRP** world and campaign grow with each issue. Whether it's adventures, new ideas or items, or discussions of rules points - if you play **WFRP**, *White Dwarf* is for you.

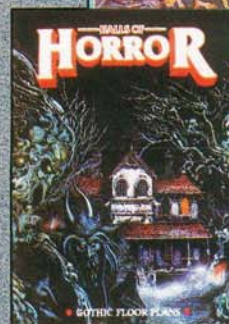
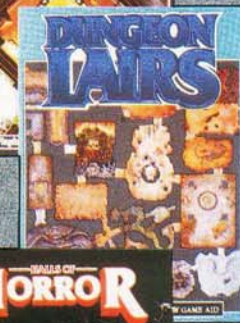
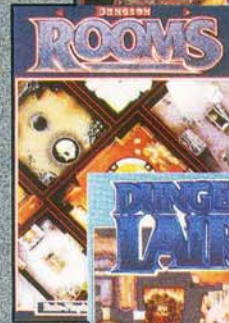
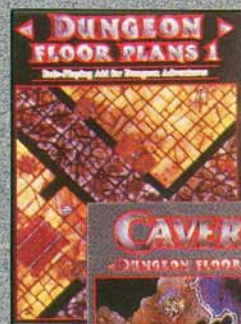

Warhammer Fantasy Roleplay
The Warhammer Campaign
Death on the Reik
Warhammer City
Power Behind the Throne
Warhammer Character Pack
Dungeon Floorplans
Dungeon Rooms
Dungeon Lairs
Caverns
Halls of Horror

Hardback Book (364pp)	£14.99
Hardback Book (138pp)	£10.99
Boxed Set (88 + 16pp)	£9.95
Hardback Book (96pp)	£8.99
Hardback Book (116pp)	£9.99
50 sheet Pack + 16pp Book	£3.99
Boxed Set	£4.95
Boxed Set	£4.95
Boxed Set	£4.95
Boxed Set	£4.95
Boxed Set	£4.95

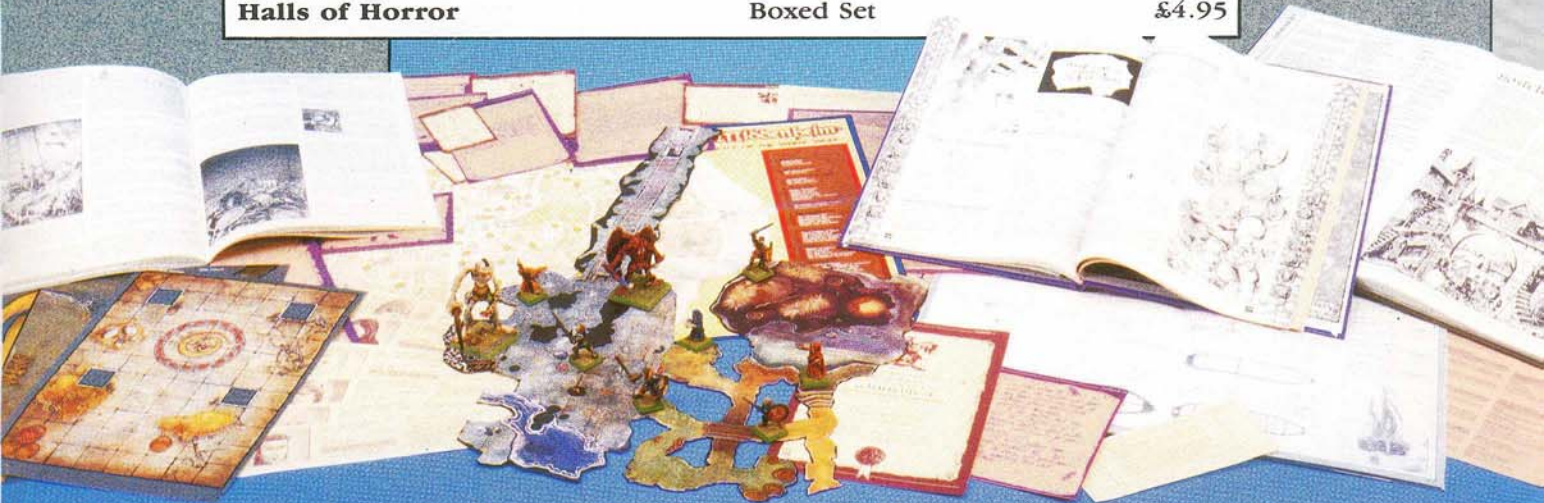

WARHAMMER
40,000

RHINO

ARMoured ASSAULT VEHICLE



THE SHAPE OF WAR TO COME

WAGE WAR WITH THE RHINO - THE MOST VERSATILE FIGHTING MACHINE OF THE 41ST MILLENNIUM! INITIALLY ACTING AS A RAPID DEPLOYMENT VEHICLE - TRANSPORTING SQUADS OF MARINES ACROSS THE BATTLEFIELDS OF COUNTLESS, WAR-TORN WORLDS - THE TECH PRIESTS OF THE ADEPTUS MECHANICUS HAVE SINCE ADAPTED IT TO A MULTIPLICITY OF COMBAT ROLES. THE RHINO IS NOW SO SUCCESSFUL THAT IT IS POSSIBLY THE MOST WIDESPREAD COMBAT VEHICLE IN THE IMPERIUM, ABLE TO TRANSPORT A FULL SQUAD OF MARINES TO ANYWHERE ON THE BATTLEFIELD.

TEN THOUSAND YEARS OF COMBAT HISTORY HAS MADE THE RHINO IDEALLY SUITED TO ITS ROLE. WELL-ARMoured, FAST AND HIGHLY MOBILE, THE TRACKED CARRIER SAFELY DELIVERS TROOPS TO WHEREVER THEY ARE NEEDED, AND WITH REINFORCED WEAPON MOUNTS, THE VEHICLE ALSO DOUBLES AS A HIGHLY MANOEUVRABLE WEAPONS' PLATFORM.

EACH BOX ENABLES YOU TO CONSTRUCT NO LESS THAN THREE COMPLETE RHINOS - MODELLED TO AWESOME DETAIL BY THE CITADEL DESIGN TEAM. PACKED WITH OPTIONAL EXTRAS (DOZER BLADES, FULL COLOUR DECALS, BOLT GUNS, SMOKE AND GRENADE LAUNCHERS), THERE'S EVEN A FULL COLOUR POSTER.

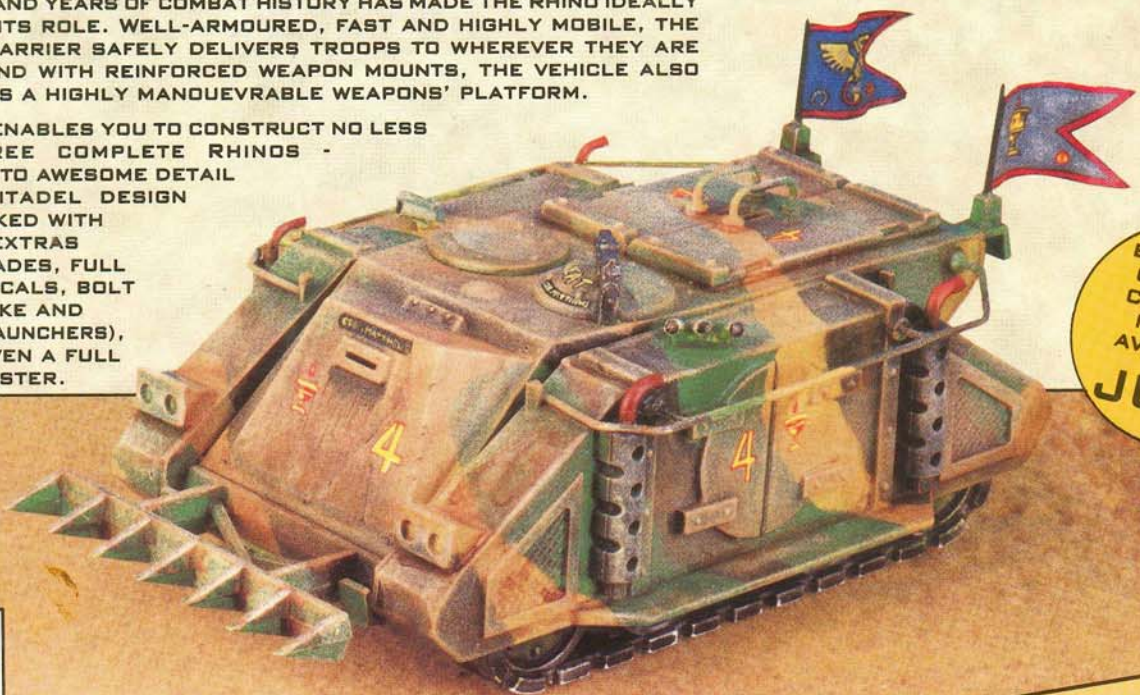

BOXED SET
OF THREE
COMPLETE
MODELS
AVAILABLE
JULY



CITADEL™
MINIATURES

MODELS SUPPLIED UNPAINTED MINIATURES NOT INCLUDED

GAMES™
WORKSHOP